

MARINE FENDER SYSTEMS

for safe berthing
of vessels

SISTEMAS DE DEFENSAS MARINAS

para atraque seguro de
buques

INDEX

pag. 03	Prosertek: Presentation Prosertek: Presentación	pag. 56	Marine fenders for special applications Defensas marinas para aplicaciones especiales
pag. 04	Close to our clients Cerca de nuestros clientes	pag. 56	ECN type fenders Defensas tipo ECN
pag. 06	The fender system company La empresa de sistemas de defensas	pag. 60	ECR type fenders Defensas tipo ECR
pag. 08	Marine fender systems: Introduction Sistemas de defensas marinas: Introducción	pag. 64	RF-E type fenders Defensas tipo RF-E
pag. 10	Solid rubber marine fenders for general applications Defensas marinas de caucho para aplicaciones generales	pag. 66	Parallel motion fenders systems Sistema defensas de movimiento paralelo
pag. 12	TCN type fenders Defensas tipo TCN	pag. 68	Pivot fenders systems Sistema de defensas pivotantes
pag. 18	SC type fenders Defensas tipo SC	pag. 70	Rubber compounds Compuestos de caucho
pag. 24	IV type fenders Defensas tipo IV	pag. 70	Introduction Introducción
pag. 30	SVA type fenders Defensas tipo SVA	pag. 71	Characteristics Características
pag. 34	SVA-P type fenders Defensas tipo SVA-P	pag. 72	Accessories Accesorios
pag. 38	C type fenders Defensas tipo C	pag. 72	Introduction Introducción
pag. 44	Floating marine fenders Defensas marinas flotantes	pag. 73	Anchors for fender fixing Anclajes para la fijación de defensas
pag. 44	FL-N type fenders Defensas tipo FL-N	pag. 74	Frontal panels Paneles frontales
pag. 48	FL-E type fenders Defensas tipo FL-E	pag. 76	UHMW-PE pads Placas de PE-UAPM
pag. 52	DON type fenders Defensas tipo DON	pag. 78	Chain assemblies Sistemas de cadenas
		pag. 80	Brackets Soportes
		pag. 81	"U" type anchors Anclajes en "U"
		pag. 82	Chains Cadenas
		pag. 83	Shackles Grilletes
		pag. 83	Tensioners Tensores



Leading European company in harbour equipment.

At Prosertek, we have over 25 years of experience in the sector. We design, manufacture, deliver, install and maintain fender systems, bollards, quick release hooks, mooring loads monitoring systems, berthing aid systems, ship access gangways, passenger boarding bridges, under the most rigorous inspection and control standards. We also provide consulting and post-sales service. This means we can offer our clients comprehensive solutions, all without having to depend on third parties. We regularly collaborate with port authorities, Oil & Gas companies, construction companies and engineering firms, from design and initial definition to turnkey installation.

Compañía europea líder en equipamiento portuario.

En Prosertek contamos con más de 25 años de experiencia en el sector. Diseñamos, fabricamos, entregamos, instalamos y mantenemos sistemas de defensas, bolardos, ganchos de escape rápido, sistemas de monitorización de cargas en amarras, sistemas de ayuda al atraque, pasarelas de acceso a buques, pasarelas de embarque de pasajeros, aplicando los sistemas de control e inspección más rigurosos. Además aconsejamos y damos servicio postventa de nuestros productos, siempre utilizando nuestros propios recursos, permitiendo ofrecer a nuestros clientes soluciones globales sin dependencias externas. Colaboramos regularmente con autoridades portuarias, compañías Oil & Gas, empresas constructoras, compañías EPCistas y firmas de ingeniería, desde el diseño y las definiciones iniciales hasta la instalación llave en mano.



Close to
our clients.

Cerca de
nuestros clientes.





Our facilities, with over 8,000 m², are in Spain, in the Bilbao area, one of the most advanced industrial zones in Europe. This is where we develop and produce each one of our solutions, providing a fast, personalised response to our clients. Our own R+D+i department brings us to the forefront of cutting-edge solutions, making Prosertek a team of highly-qualified professionals.

We offer "turnkey" solutions, so that our clients can enjoy the benefits of delegating management of the entire project to our team, guaranteeing perfect coordination and eliminating cost increases stemming from diversification of responsibilities.

Nuestras instalaciones, de más de 8000 m², se encuentran en España, en el entorno del Gran Bilbao, una de las áreas industriales más avanzadas de Europa, donde desarrollamos y producimos cada una de nuestras soluciones ofreciendo una respuesta rápida y personalizada a nuestros clientes. Nuestro departamento propio de I+D+i nos permite estar a la vanguardia de las últimas soluciones, haciendo de Prosertek un equipo de profesionales altamente cualificados.

Ofrecemos soluciones "Llave en mano", posibilitando a nuestros clientes disfrutar de las ventajas de delegar en nuestro equipo la gestión íntegra de los proyectos, lo que garantiza una perfecta coordinación y elimina incrementos de coste derivados de la diversificación de responsabilidades.

-  Headquarters and regional centres
Oficinas centrales y sedes regionales
-  Our projects
Nuestros proyectos



THE FENDER SYSTEM COMPANY

LA EMPRESA DE SISTEMAS DE DEFENSAS

With more than 25 years' experience, Prosertek can cater for all marine fender systems solutions.

Prosertek can showcase TENS OF THOUSANDS of successfully installed and operating fender systems world-wide. These installations are our best company presentation and demonstrate that Prosertek is a world leading European company.

The acquired experience resides in our highly motivated and professional staff, the real "brain and soul" of our company.

En más de sus 25 años de existencia, Prosertek ha creado todo tipo de soluciones de sistemas de defensas marinas.

DECENAS DE MILES de sistemas diseñados e instalados que funcionan satisfactoriamente, son nuestra mejor carta de presentación. Sin lugar a dudas somos la empresa europea líder mundial.

La experiencia adquirida reside en nuestro personal altamente cualificado y profesional, el verdadero "cerebro y alma" de nuestra empresa.

At Prosertek we listen to our customers' needs and analyse their requirements in order to design and deliver HIGH QUALITY, CUSTOMISED SOLUTIONS.

Prosertek is able to participate at all stages of the project life cycle. We advise on fender system designs and contribute to specifications through the selection of appropriate fender types, using PIANC guidelines to govern calculation of berthing energies, steel panel construction and size/grade of accessories such as chains and fixing hardware. We manufacture, deliver and assist on site through installation, training and maintenance supervision. At all stages Prosertek follows industry standards and applicable local standards and laws.

En Prosertek escuchamos las necesidades de nuestros clientes y analizamos sus requerimientos para diseñar y entregar SOLUCIONES PERSONALIZADAS DE ALTA CALIDAD.

Prosertek puede participar en todas las etapas del ciclo de vida del proyecto. Asesoramos sobre los diseños de sistemas de defensas y contribuimos a la definición de las especificaciones mediante la selección de las tipologías de defensas adecuadas, aplicando las recomendaciones de PIANC. Calculamos las energías de atraque, diseñamos y fabricamos los paneles de acero y los accesorios tales como cadenas y elementos de fijación. Fabricamos, entregamos e instalamos o supervisamos la instalación y tenemos capacidad de formar al personal del cliente. En todas las etapas de proyecto, Prosertek sigue los estándares internacionales y las normas específicas de cada cliente o de cada proyecto.



INTRODUCTION

Marine fender systems are the interface between berthing vessels and berth structures. The main function of marine fender systems is to absorb and transform a vessel's kinetic energy into reaction forces which can be supported by the berthing structure and vessel's hull.

Properly designed fender systems must be able to bring a berthing vessel to a complete halt without damaging the berth structure, the vessel or the fender system itself. A properly designed fender system will also protect a moored vessel and berth structure from the motions caused by winds, waves, water currents, tidal changes and port operations such as loading/unloading of cargo.

Fender systems are designed as a combination of fender unit/s, a frontal panel with low friction facings and accessories such as chains, anchors and berth-to-fender connection structures. Elastomeric rubber units are components in the fender systems for absorbing and transforming vessels' kinetic energy into reaction forces. Other type of units containing compressed air or polyethylene foam, also may be employed.

This catalogue contains generic information covering the most common fender units designed and manufactured by Prosertek. It also contains basic information covering fender systems components such as frontal frames, low friction polyethylene pads, anchors, chains, shackles, tensioners, brackets, etc.

Common characteristics of all Prosertek fender systems are high quality, stability even in the most sever conditions, trouble free service life and minimum maintenance. Tens of thousands of fenders manufactured in our facilities in Europe and installed all over the world are testament this.

It is important to bear in mind that, in most cases, no single solution to fendering exists. Each project must be judged on its specific requirements, being a combination of vessels, structure type/use, berthing and environmental conditions. Prosertek is an experienced marine fender system designer and manufacturer, and we welcome input from berth designers, operators and installers.



Due to our policy of continuous improvement and development, all technical data in this document is subject to changes without prior notification.

Errors and omissions excepted.

INTRODUCCIÓN

Los sistemas de defensas marinas son el interfaz seguro entre los buques y los muelles. Su función principal es la de absorber y transformar la energía cinética que desarrolla el buque durante el atraque, en fuerzas de reacción que se transmiten y soportan tanto por la estructura de muelle como por el casco de buque.

Deben ser capaces de detener completamente el buque sin dañar ni la estructura de muelle, ni el buque, ni a sí mismo. También deben de proteger el muelle, los buques y a si mismo de los movimientos causados por vientos, olas, corrientes de agua, mareas y operaciones portuarias como carga/descarga de los buques, mientras los buques están amarrados.

Los sistemas de defensas se diseñan como combinación de unidad/es de defensa, panel frontal y accesorios tales como cadenas, anclajes y estructuras de conexión muelle-defensa/s. Las unidades de defensa son los principales elementos de sistema que permiten la absorción y transformación de la energía cinética en fuerzas de reacción. Los materiales: compuesto de caucho, aire comprimido, espuma de polietileno reticulado y las geometrías: cónica, circular o cilíndrica, son variables para la realización de tal tarea.

Este catálogo contiene información sobre las unidades de defensa más comunes diseñadas y fabricadas por Prosertek. También contiene la información básica del resto de componentes de los sistemas de defensas marinas tales como paneles frontales, placas de polietileno de ultra alto peso molecular, anclajes, cadenas, grilletes, tensores, soportes, etc.

Las características comunes de todos los sistemas de defensas de Prosertek son su calidad, su buen funcionamiento en las condiciones más severas y su elevada vida útil con el mínimo mantenimiento. Decenas de miles de defensas fabricadas en nuestras instalaciones en Europa e instaladas en todo el mundo lo demuestran.

Es importante, tener en cuenta, que, en la mayoría de los casos, no existe una única solución para elegir el sistema de defensa más adecuado. Es una buena práctica consultar a Prosertek, aprovechando nuestra experiencia en diseño y fabricación de sistemas de defensas marinas.



Debido a nuestra política de mejora continua, la información contenida en este documento está sujeta a cambios sin previo aviso.

A pesar del esfuerzo invertido en preparar este documento, el mismo puede contener errores u omisiones.

INTRODUCTION

DESIGN / DISEÑO:

The design, production and testing of our marine fender systems is based on Guidelines for the Design of Fender Systems:2002 edited by MarcCom Work Group 33 of PIANC (World Association for Waterborne Transport Infrastructure), European standard: Eurocode 3 (EN 1993) - standard for the design of steel structures, British standard BS 6349 Maritime works - Part 4: Code of practice for design of fendering and mooring systems, and the state of art of other related standards and recommendations.

Anchorages are calculated considering the worst load combination, material grade, adherence of surface, etc.

Upon request, Prosertek can design and manufacture fender systems according to other national and/or international standards, or implementing clients' specific standards.

El diseño, la producción y los ensayos de nuestros sistemas de defensas marinas están basados en las recomendaciones para el diseño de sistemas de defensas (Guidelines for the Design of Fender Systems:2002) publicado por el grupo de trabajo 33 de PIANC (World Association for Waterborne Transport Infrastructure), el estándar europeo Eurocódigo 3 (EN 1993) – aplicable al diseño de estructuras de acero, la norma BS 6349 Parte 4 – Código de prácticas para diseño de sistemas de atraque y amarre, y las últimas revisiones de otros estándares y recomendaciones relacionados.

Los anclajes están calculados teniendo en cuenta la combinación de cargas más desfavorable posible, materiales, adherencia de la superficie, etc.

Bajo demanda, Prosertek puede diseñar y fabricar sistemas de defensas de acuerdo con otros estándares nacionales y/o internacionales, o adoptándonos a las normativas específicas de nuestros clientes.

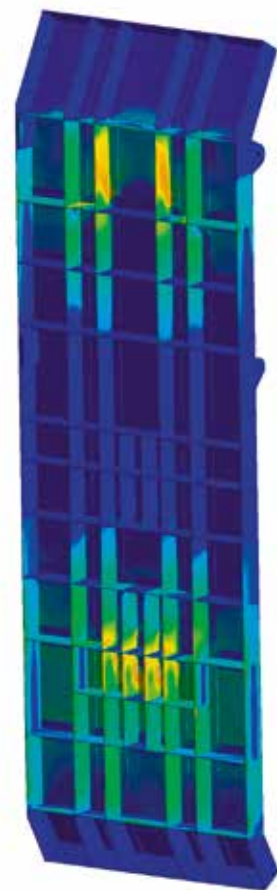
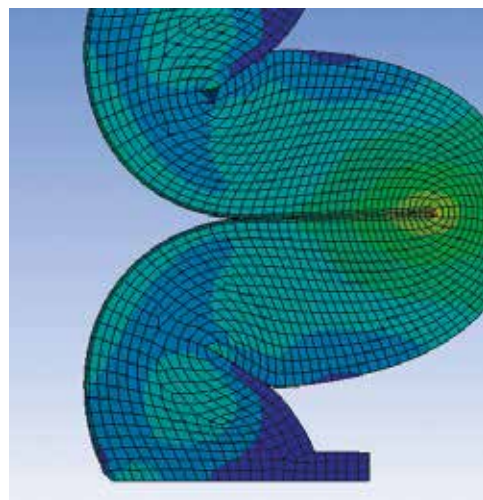

INTRODUCCIÓN

QA/QC / CALIDAD:

Quality is the most essential aspect of our marine fender systems. Quality of raw materials and finished products are comprehensively checked and recorded at all stages.

La calidad es la parte esencial de nuestros sistemas de defensas marinas controlándose antes (diseño, materia prima), durante y después de su fabricación.



TCN TYPE FENDERS

DEFENSAS TIPO TCN



Features:

- Good energy absorption to reaction force ratio E/R
- Good multi-directional angle performance
- Strong and durable
- Supports large frames
- Easy installation
- Wide range of sizes and grades

Applications:

- All type of berths (coastal, river, tidal & non-tidal)
- All kind of berths structure (open, semi-open, closed, monopiles, dolphins)
- All types of terminals:
 - Oil and gas
 - Container
 - Bulk
 - General cargo
 - RoRo & cruise
- In parallel motion systems
- Offshore platforms

Características:

- Buen ratio energía-reacción E/R
- Buenas características angulares en todas las direcciones
- Robustas y duraderas
- Soportan grandes paneles
- Instalación sencilla
- Gran rango de tamaños y grados

Aplicaciones:

- Todo tipo de atraques (costeros, fluviales, sometidos o no a carrera de mareas)
- Todo tipo de estructuras (abiertas, semi-abiertas, cerradas, monopilotes, duques de alba)
- Todo tipo de terminales:
 - Petroleo y gas
 - Contenedores
 - Granel
 - Carga general
 - RoRo y cruceros
- Para sistemas de movimiento paralelo
- Plataformas offshore



DIMENSIONS / DIMENSIONES:

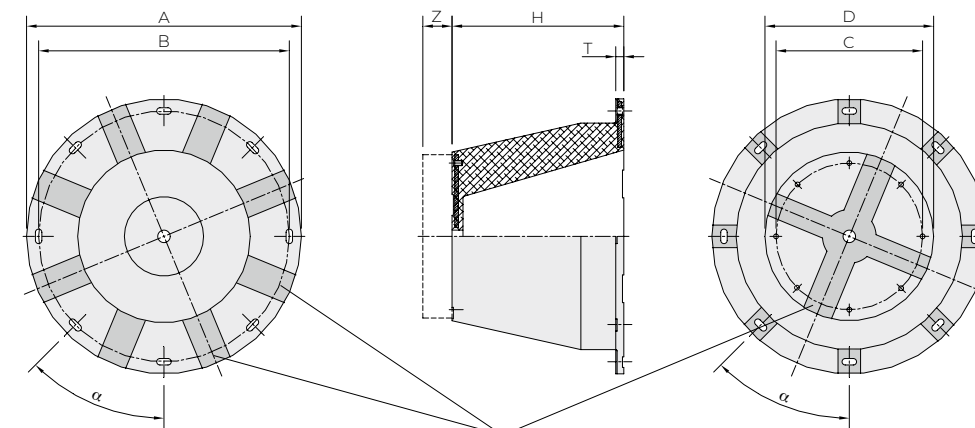

Grooves for water exit
Ranuras para salidas de agua

Fender Defensa []	H [mm]	ØA [mm]	ØB [mm]	ØC [mm]	ØD [mm]	T [mm]	Z [mm]	Anchors Anclajes [n° x M]	α [°]	Weight Peso [kg]
TCN-300	300	520	450	245	295	20	51	4xM20	90	33
TCN-400	400	670	585	340	393	28	68	4xM24	90	78
TCN-500	500	820	730	425	491	35	85	4xM24	90	172
TCN-600	600	960	875	515	589	50	102	4xM30	90	250
TCN-700	700	1120	1020	600	685	55	119	4xM30	90	378
TCN-800	800	1280	1165	685	785	55	136	6xM30	60	590
TCN-900	900	1440	1313	770	885	55	153	6xM36	60	846
TCN-950	950	1520	1390	815	930	60	160	6xM36	60	974
TCN-1000	1000	1600	1460	855	982	70	170	6xM36	60	1123
TCN-1050	1050	1680	1530	900	1030	70	179	6xM36	60	1343
TCN-1100	1100	1760	1605	940	1080	70	187	8xM36	45	1525
TCN-1150	1150	1840	1680	985	1130	70	196	8xM39	45	1690
TCN-1200	1200	1920	1750	1025	1175	70	204	8xM42	45	1889
TCN-1300	1300	2080	1900	1100	1275	70	221	8xM48	45	2354
TCN-1400	1400	2240	2040	1195	1370	70	238	8xM48	45	2855
TCN-1600	1600	2560	2335	1365	1571	75	272	8xM48	45	4438
TCN-1800	1800	2880	2625	1525	1765	80	306	10xM56	36	6317
TCN-2000	2000	3200	2920	1710	1964	110	340	10xM56	36	8987
TCN-2500	2500	4000	2450	2150	3650	140	380	12xM76	30	17900

- See page 73 for different types of anchors / para diferentes tipos de anclajes ver página 73

TCN TYPE FENDERS

DEFENSAS TIPO TCN

PERFORMANCE DATA / CARACTERÍSTICAS:

Size Tamaño	Grade Grado	E1	E2	E3	E4	E5	D1	D2	D3	D4	D5	C1	C2
TCN-300	E [kNm] R [kN]	10,7 63,4	11,0 65,2	11,2 66,4	11,5 68,2	11,8 70,1	12,0 71,3	12,6 74,4	13,0 76,8	13,5 79,9	14,0 83,0	14,4 85,4	14,8 87,3
TCN-400	E [kNm] R [kN]	24,9 110,3	25,5 113,0	26,3 116,2	27,0 119,4	27,7 122,6	28,4 125,8	29,4 129,9	30,3 134,0	31,3 138,5	32,2 142,7	33,2 146,8	33,9 149,9
TCN-500	E [kNm] R [kN]	47,9 169,8	49,3 175,0	50,8 180,1	52,1 184,8	53,6 189,9	54,9 194,7	56,5 200,5	58,2 206,4	59,8 212,2	61,5 218,1	63,1 223,9	64,8 229,7
TCN-600	E [kNm] R [kN]	81,5 240,3	83,8 247,3	86,1 254,0	88,5 261,0	90,7 267,7	93,1 274,7	95,5 281,7	97,7 288,3	100,1 295,3	102,4 302,0	104,8 309,0	108,3 319,3
TCN-700	E [kNm] R [kN]	150,0 379,7	154,1 390,1	158,3 400,8	162,4 411,2	166,6 421,6	170,8 432,3	174,7 442,2	178,6 452,2	182,5 462,1	186,4 472,0	190,3 481,9	195,0 493,6
TCN-800	E [kNm] R [kN]	217,2 480,6	223,6 494,7	230,0 508,8	236,4 523,0	242,9 537,3	249,3 551,5	255,4 565,1	261,6 578,8	267,8 592,5	274,0 606,2	280,2 619,8	287,7 636,5
TCN-900	E [kNm] R [kN]	311,6 613,3	319,5 628,9	327,4 644,6	335,4 660,2	343,3 675,8	351,2 691,4	359,2 707,0	367,1 722,6	375,0 738,2	383,0 753,8	390,9 769,5	401,8 791,0
TCN-950	E [kNm] R [kN]	364,8 680,3	374,3 697,9	383,9 715,8	393,4 733,4	402,9 751,3	412,4 769,0	422,2 787,2	431,9 805,3	441,7 823,5	451,3 841,6	461,1 859,8	473,8 883,4
TCN-1000	E [kNm] R [kN]	422,9 748,5	434,2 768,6	445,5 788,5	456,8 808,5	468,0 828,4	479,4 848,4	490,6 868,3	501,9 888,4	513,1 908,2	524,5 928,3	535,7 948,1	550,4 974,2
TCN-1050	E [kNm] R [kN]	488,4 824,0	501,4 845,9	514,4 867,8	527,5 889,8	540,4 911,7	553,5 933,8	566,3 955,3	579,1 976,9	591,8 998,4	604,7 1020	617,5 1042	634,4 1070
TCN-1100	E [kNm] R [kN]	561,4 903,9	576,6 928,5	591,8 953,0	607,2 977,8	622,4 1002	637,7 1027	652,7 1051	667,7 1075	682,8 1100	697,8 1124	713,0 1148	732,0 1179
TCN-1150	E [kNm] R [kN]	640,4 986,3	657,3 1013	674,4 1039	691,5 1065	708,6 1092	725,6 1118	742,7 1144	759,8 1170	776,9 1197	794,0 1223	811,0 1249	833,3 1284
TCN-1200	E [kNm] R [kN]	729,8 1078	749,5 1107	769,3 1136	789,1 1166	808,8 1195	828,5 1224	848,1 1253	867,7 1282	887,1 1310	906,7 1339	926,3 1368	950,9 1405
TCN-1300	E [kNm] R [kN]	922,0 1256	946,6 1290	971,2 1323	995,7 1357	1020 1390	1045 1424	1069 1457	1094 1491	1119 1524	1143 1558	1168 1591	1200 1635
TCN-1400	E [kNm] R [kN]	1146 1450	1177 1489	1207 1528	1238 1567	1269 1606	1299 1645	1330 1683	1360 1722	1391 1760	1421 1799	1452 1838	1491 1888
TCN-1600	E [kNm] R [kN]	1692 1874	1738 1924	1783 1975	1829 2026	1875 2077	1921 2127	1967 2178	2012 2228	2058 2279	2104 2329	2149 2380	2208 2445
TCN-1800	E [kNm] R [kN]	2390 2359	2462 2423	2526 2486	2591 2550	2656 2614	2720 2678	2785 2741	2850 2805	2915 2869	2979 2932	3044 2996	3127 3078
TCN-2000	E [kNm] R [kN]	3275 2901	3363 2979	3450 3056	3537 3133	3625 3211	3712 3288	3800 3365	3887 3443	3974 3520	4062 3597	4149 3675	4262 3775
TCN-2500	E [kNm] R [kN]	5576 3952	5725 4057	5874 4163	6023 4268	6172 4374	6320 4479	6469 4585	6617 4690	6766 4795	6915 4901	7063 5006	7257 5143

C3	C4	C5	B1	B2	B3	B4	B5	A1	A2	A3	A4	A5	Grade Grado	Size Tamaño
15,0 88,5	15,2 89,7	15,4 91,0	15,7 92,8	15,9 94,0	16,1 95,3	16,4 97,1	16,6 98,3	16,8 99,6	17,0 100,8	17,3 102,1	17,5 103,4	17,7 104,6	E [kNm] R [kN]	TCN-300
34,6 153,1	35,3 156,3	36,1 159,5	36,8 162,7	37,7 166,8	38,6 170,9	39,6 175,0	40,5 179,1	41,5 183,7	42,6 188,3	43,6 193,1	44,8 198,0	45,9 203,1	E [kNm] R [kN]	TCN-400
66,4 235,6	68,1 241,4	69,6 246,9	71,3 252,8	72,9 258,6	74,6 264,4	76,2 270,3	77,9 276,1	79,5 282,0	81,2 287,9	82,9 294,0	84,7 300,3	86,5 306,6	E [kNm] R [kN]	TCN-500
111,8 329,7	115,3 340,0	118,8 350,3	122,3 360,7	125,7 370,7	129,2 381,0	132,7 391,3	136,2 401,7	139,7 412,0	143,3 422,6	146,9 433,5	150,7 444,6	154,6 456,0	E [kNm] R [kN]	TCN-600
199,6 505,4	204,1 516,8	208,8 528,6	213,4 540,3	218,1 552,0	222,7 563,8	227,2 575,2	231,9 587,0	236,5 598,7	241,2 610,7	246,0 622,9	251,0 635,3	256,0 648,0	E [kNm] R [kN]	TCN-700
295,2 653,1	302,7 669,7	310,3 686,6	317,9 703,2	325,2 719,4	332,5 735,6	339,8 751,8	347,1 767,9	354,4 784,1	361,9 800,6	369,5 817,5	377,3 834,7	385,2 852,3	E [kNm] R [kN]	TCN-800
412,6 812,2	423,5 833,7	434,4 855,0	445,3 876,5	455,9 897,4	466,6 918,5	477,2 939,4	487,9 960,5	498,5 981,3	509,4 1003	520,4 1025	531,8 1047	543,3 1070	E [kNm] R [kN]	TCN-900
486,5 907,1	499,2 930,9	511,9 954,5	524,6 978,1	537,2 1002	549,9 1025	562,7 1049	575,4 1073	588,0 1096	601,0 1121	614,2 1145	627,7 1171	641,6 1196	E [kNm] R [kN]	TCN-950
565,1 1000	579,7 1026	594,4 1052	609,0 1078	623,7 1104	638,4 1130	653,0 1156	667,6 1182	682,4 1208	697,4 1234	712,8 1262	728,5 1290	744,6 1318	E [kNm] R [kN]	TCN-1000
651,2 1099	668,1 1127	684,8 1155	701,7 1184	718,5 1212	735,4 1241	752,2 1269	769,1 1298	785,9 1326	803,0 1355	820,6 1384	838,5 1415	856,8 1445	E [kNm] R [kN]	TCN-1050
751,1 1210	770,1 1240	789,3 1271	808,3 1302	827,4 1332	846,6 1363	865,6 1394	884,7 1425	903,8 1455	923,4 1487	943,4 1519	963,8 1552	984,7 1586	E [kNm] R [kN]	TCN-1100
855,4 1318	877,7 1352	899,8 1386	922,1 1420	944,2 1454	966,4 1489	988,6 1523	1011 1557	1033 1591	1056 1626	1079 1662	1102 1698	1127 1735	E [kNm] R [kN]	TCN-1150
975,6 1441	1000 1478	1025 1514	1050 1551	1074 1587	1099 1624	1124 1660	1149 1697	1173 1733	1199 1770	1224 1808	1251 1847	1278 1887	E [kNm] R [kN]	TCN-1200
1232 1678	1264 1722	1296 1765	1328 1809	1359 1852	1391 1895	1423 1939	1455 1982	1486 2025	1519 2069	1552 2115	1586 2161	1621 2208	E [kNm] R [kN]	TCN-1300
1531 1938	1570 1988	1610 2038	1650 2088	1689 2138	1728 2188	1768 2238	1807 2288	1847 2337	1887 2388	1928 2440	1970 2494	2013 2548	E [kNm] R [kN]	TCN-1400
2266 2509	2324 2574	2383 2639	2441 2703	2500 2768	2558 2833	2616 2898	2675 2962	2733 3027	2793 3093	2854 3160	2916 3229	2980 3300	E [kNm] R [kN]	TCN-1600
3210 3159	3293 3241	3376 3323	3459 3404	3541 3486	3624 3567	3707 3648	3789 3730	3872 3811	3957 3895	4043 3980	4132 4067	4222 4156	E [kNm] R [kN]	TCN-1800
4376 3876	4490 3977	4603 4077	4717 4178	4830 4278	4944 4379	5057 4479	5171 4580	5284 4681	5400 4783	5519 4888	5640 4996	5764 5105	E [kNm] R [kN]	TCN-2000
7450 5280	7643 5417	7837 5554	8030 5691	8224 5828	8417 5965	8610 6102	8804 6239	8997 6376	9195 6517	9397 6660	9603 6806	9814 6956	E [kNm] R [kN]	TCN-2500

- RPD (Rated Performance Data) values: impact velocity 150mm/s, temperature 23°C, impact angle 0°, for most common used rubber compound: blend of natural rubber (NR) and styrene-butadiene rubber (SBR)

- Valores RPD (Rated Performance Data): velocidad de impacto 150mm/s, temperatura 23°C, ángulo de impacto 0°, para el compuesto de caucho más usado: mezcla de caucho natural (NR) y caucho estireno-butadieno (SBR)

- RPD (Rated Performance Data) values: impact velocity 150mm/s, temperature 23°C, impact angle 0°, for most common used rubber compound: blend of natural rubber (NR) and styrene-butadiene rubber (SBR)

- Valores RPD (Rated Performance Data): velocidad de impacto 150mm/s, temperatura 23°C, ángulo de impacto 0°, para el compuesto de caucho más usado: mezcla de caucho natural (NR) y caucho estireno-butadieno (SBR)

CHARACTERISTIC PERFORMANCE CURVE / CURVA CARACTERÍSTICA DE RENDIMIENTO:

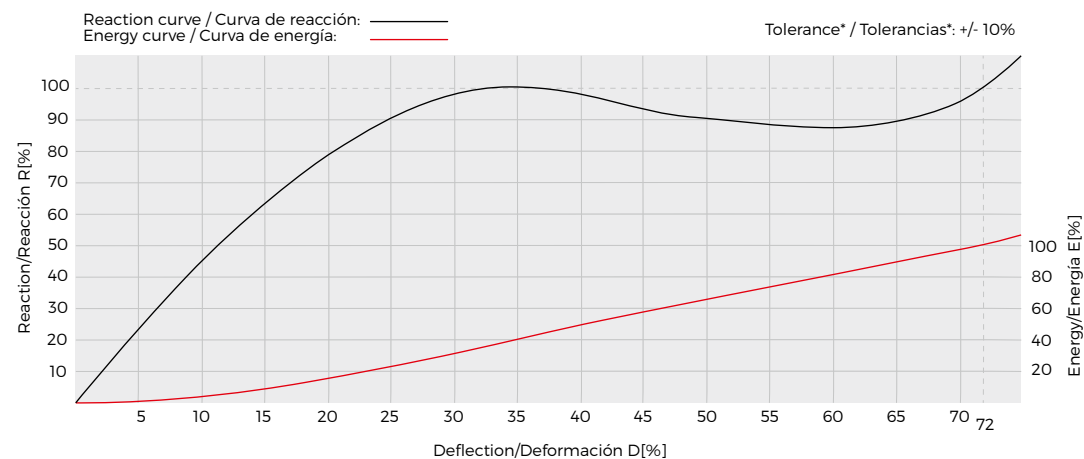

* Standard Reaction & Energy tolerances, tighter tolerances upon request
* Tolerancias de Reacción y Energía estándar, tolerancias más restrictivas bajo demanda

Reaction & Energy percentage values at intermediate Deflections Valores porcentuales de Reacción y Energía en Deformaciones intermedias																	
Deflection / Deformación	D [%]	5	10	15	20	25	30	35	40	45	50	55	60	65	70	72	75
Reaction / Reacción	R [%]	23	45	63	78	90	98	100	98	93	90	88	87	89	95	100	110
Energy / Energía	E [%]	1	4	9	15	23	31	40	49	57	65	73	81	88	97	100	106

TCN TYPE FENDERS

DEFENSAS TIPO TCN

CORRECTION FACTORS / FACTORES DE CORRECCIÓN:

Velocity correction factors* / Factores de corrección de velocidad*

VF	Impact Velocity / Velocidad de impacto											
	Size Tamaño	1 [mm/s]	25 [mm/s]	50 [mm/s]	100 [mm/s]	150 [mm/s]	200 [mm/s]	250 [mm/s]	300 [mm/s]	350 [mm/s]	400 [mm/s]	450 [mm/s]
TCN-300	0,858	0,913	0,946	0,980	1	1,015	1,026	1,036	1,044	1,051	1,058	1,063
TCN-400	0,871	0,913	0,946	0,980	1	1,015	1,026	1,036	1,044	1,051	1,058	1,063
TCN-500	0,881	0,913	0,946	0,980	1	1,015	1,026	1,036	1,044	1,051	1,058	1,063
TCN-600	0,889	0,913	0,946	0,980	1	1,015	1,026	1,036	1,044	1,051	1,058	1,063
TCN-700	0,896	0,913	0,946	0,980	1	1,015	1,026	1,036	1,044	1,051	1,058	1,063
TCN-800	0,902	0,913	0,946	0,980	1	1,015	1,026	1,036	1,044	1,051	1,058	1,063
TCN-900	0,907	0,913	0,946	0,980	1	1,015	1,026	1,036	1,044	1,051	1,058	1,063
TCN-950	0,910	0,913	0,946	0,980	1	1,015	1,026	1,036	1,044	1,051	1,058	1,063
TCN-1000	0,912	0,913	0,946	0,980	1	1,015	1,026	1,036	1,044	1,051	1,058	1,063
TCN-1050	0,915	0,915	0,946	0,980	1	1,015	1,026	1,036	1,044	1,051	1,058	1,063
TCN-1100	0,917	0,917	0,946	0,980	1	1,015	1,026	1,036	1,044	1,051	1,058	1,063
TCN-1150	0,919	0,919	0,946	0,980	1	1,015	1,026	1,036	1,044	1,051	1,058	1,063
TCN-1200	0,921	0,921	0,946	0,980	1	1,015	1,026	1,036	1,044	1,051	1,058	1,063
TCN-1300	0,925	0,925	0,946	0,980	1	1,015	1,026	1,036	1,044	1,051	1,058	1,063
TCN-1400	0,928	0,928	0,946	0,980	1	1,015	1,026	1,036	1,044	1,051	1,058	1,063
TCN-1600	0,935	0,935	0,946	0,980	1	1,015	1,026	1,036	1,044	1,051	1,058	1,063
TCN-1800	0,940	0,940	0,946	0,980	1	1,015	1,026	1,036	1,044	1,051	1,058	1,063
TCN-2000	0,945	0,945	0,946	0,980	1	1,015	1,026	1,036	1,044	1,051	1,058	1,063
TCN-2500	0,956	0,956	0,956	0,980	1	1,015	1,026	1,036	1,044	1,051	1,058	1,063

Temperature correction factors* / Factores de corrección de temperatura*

Temperature [°C] Temperatura [°C]	-30	-20	-10	0	+10	+23	+30	+40	+50
TF	1,35	1,25	1,16	1,09	1,04	1	0,97	0,94	0,91

Angle correction factors* / Factores de corrección de ángulo*

Angle [°] Ángulo [°]	0	3	5	8	10	15	20
AF (Energy / Energía)	1	1,03	1,04	1,02	1,00	0,90	0,80
AF (Reaction / Reacción)	1	1	1	1	1	1	1

* Values for correction factors correspond to the most used rubber compound: blend of natural rubber (NR) and styrene-butadiene rubber (SBR)

* Los valores de los factores de corrección corresponden al compuesto de caucho más usado: mezcla de caucho natural (NR) y caucho estireno-butadieno (SBR)

INSTALLATION CLEARANCES / ESPACIO NECESARIO PARA LA INSTALACIÓN:

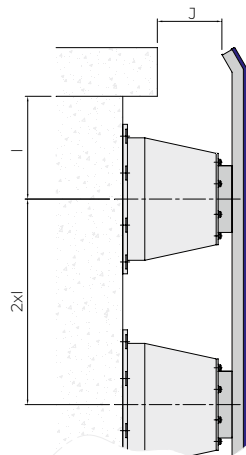

Size Tamaño	I [mm]	J [mm]
TCN-300	330	240
TCN-400	440	320
TCN-500	550	400
TCN-600	660	480
TCN-700	770	560
TCN-800	880	640
TCN-900	990	720
TCN-950	1045	760
TCN-1000	1100	800
TCN-1050	1155	840

Size Tamaño	I [mm]	J [mm]
TCN-1100	1210	880
TCN-1150	1265	920
TCN-1200	1320	960
TCN-1300	1430	1040
TCN-1400	1540	1120
TCN-1600	1760	1280
TCN-1800	1980	1440
TCN-2000	2200	1600
TCN-2500	2750	2000

WEIGHT SUPPORT CAPACITY / CAPACIDAD DE SOPORTAR PESO:

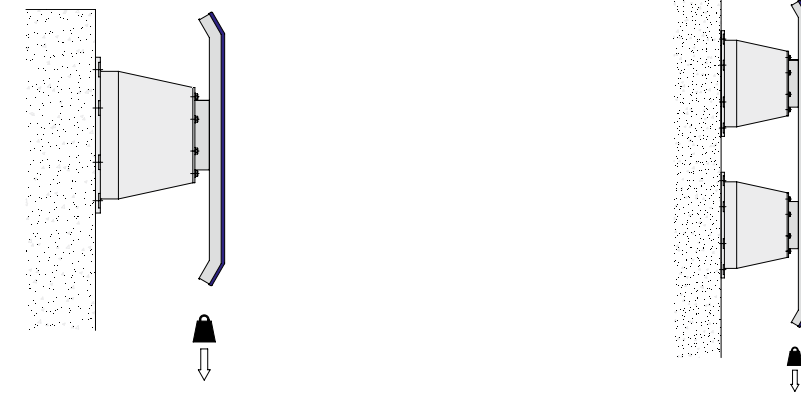

Single or multiple horizontal Una o varias horizontalmente	Grades / Grados				
	Size Tamaño []	E [kg]	D [kg]	C [kg]	B [kg]
TCN-300	n x 36	n x 40	n x 43	n x 46	n x 50
TCN-400	n x 86	n x 94	n x 101	n x 109	n x 117
TCN-500	n x 189	n x 206	n x 224	n x 241	n x 258
TCN-600	n x 275	n x 300	n x 325	n x 350	n x 375
TCN-700	n x 416	n x 454	n x 491	n x 529	n x 567
TCN-800	n x 649	n x 708	n x 767	n x 826	n x 885
TCN-900	n x 931	n x 1015	n x 1100	n x 1184	n x 1269
TCN-950	n x 1071	n x 1169	n x 1266	n x 1364	n x 1461
TCN-1000	n x 1235	n x 1348	n x 1460	n x 1572	n x 1685
TCN-1050	n x 1477	n x 1612	n x 1746	n x 1880	n x 2015
TCN-1100	n x 1678	n x 1830	n x 1983	n x 2135	n x 2288
TCN-1150	n x 1859	n x 2028	n x 2197	n x 2366	n x 2535
TCN-1200	n x 2078	n x 2267	n x 2456	n x 2645	n x 2834
TCN-1300	n x 2589	n x 2825	n x 3060	n x 3296	n x 3531
TCN-1400	n x 3141	n x 3426	n x 3712	n x 3997	n x 4283
TCN-1600	n x 4882	n x 5326	n x 5769	n x 6213	n x 6657
TCN-1800	n x 6949	n x 7580	n x 8212	n x 8844	n x 9476
TCN-2000	n x 9886	n x 10784	n x 11683	n x 12582	n x 13481
TCN-2500	n x 19690	n x 21480	n x 23270	n x 25060	n x 26850

n ≥ 1

Multiple vertical Varias verticalmente	Grades / Grados				
	Size Tamaño []	E [kg]	D [kg]	C [kg]	B [kg]
TCN-300	n x 46	n x 53	n x 56	n x 59	n x 63
TCN-400	n x 109	n x 125	n x 133	n x 140	n x 148
TCN-500	n x 241	n x 275	n x 292	n x 310	n x 327
TCN-600	n x 350	n x 400	n x 425	n x 450	n x 475
TCN-700	n x 529	n x 605	n x 643	n x 680	n x 718
TCN-800	n x 826	n x 944	n x 1003	n x 1062	n x 1121
TCN-900	n x 1184	n x 1354	n x 1438	n x 1523	n x 1607
TCN-950	n x 1364	n x 1558	n x 1656	n x 1753	n x 1851
TCN-1000	n x 1572	n x 1797	n x 1909	n x 2021	n x 2134
TCN-1050	n x 1880	n x 2149	n x 2283	n x 2417	n x 2552
TCN-1100	n x 2135	n x 2440	n x 2593	n x 2745	n x 2898
TCN-1150	n x 2366	n x 2704	n x 2873	n x 3042	n x 3211
TCN-1200	n x 2645	n x 3022	n x 3211	n x 3400	n x 3589
TCN-1300	n x 3296	n x 3766	n x 4002	n x 4237	n x 4473
TCN-1400	n x 3997	n x 4568	n x 4854	n x 5139	n x 5425
TCN-1600	n x 6213	n x 7101	n x 7545	n x 7988	n x 8432
TCN-1800	n x 8844	n x 10107	n x 10739	n x 11371	n x 12002
TCN-2000	n x 12582	n x 14379	n x 15278	n x 16177	n x 17075
TCN-2500	n x 25060	n x 28640	n x 30430	n x 32220	n x 34010

n ≥ 2

DIMENSIONAL TOLERANCES / TOLERANCIAS DIMENSIONALES:

Dimension / Dimensión	Tolerances / Tolerancias
General dimensions / Dimensiones generales	±3% or 2mm* ±3% o 2mm*
Bolt holes spacing / Distancia entre agujeros de fijación	±4mm (non-cumulative) ±4mm (no-acumulativo)
Flange thickness / Espesor brida	±15mm
Bolt hole diameter / Diámetro agujeros de fijación	±5mm

* whichever is greater dimension
* la dimension mayor

SC TYPE FENDERS DEFENSAS TIPO SC



Features:

- High deformation capacity
- Strong and durable
- Good multi-directional angular performance
- Supports large frames
- Easy installation
- Wide range of sizes

Applications:

- All type of berths (coastal, river, tidal & non-tidal)
- All kind of berth structures (open, semi-open, closed, monopiles, dolphins)
- All types of terminals:
 - Oil and gas
 - Container
 - Bulk
 - General cargo
 - RoRo & cruise
- Offshore platforms

Características:

- Alta capacidad de deformación
- Robustas y duraderas
- Buenas características angulares en todas las direcciones
- Soportan grandes paneles
- Instalación sencilla
- Gran rango de dimensiones

Aplicaciones:

- Todo tipo de atraques (costeros, fluviales, sometidos o no a carrera de mareas)
- Todo tipo de estructuras (abiertas, semi-abiertas, cerradas, monopilotes, duques de alba)
- Todo tipo de terminales:
 - Petroleo y gas
 - Contenedores
 - Granel
 - Carga general
 - RoRo y cruceros
- Plataformas offshore

DIMENSIONS / DIMENSIONES:

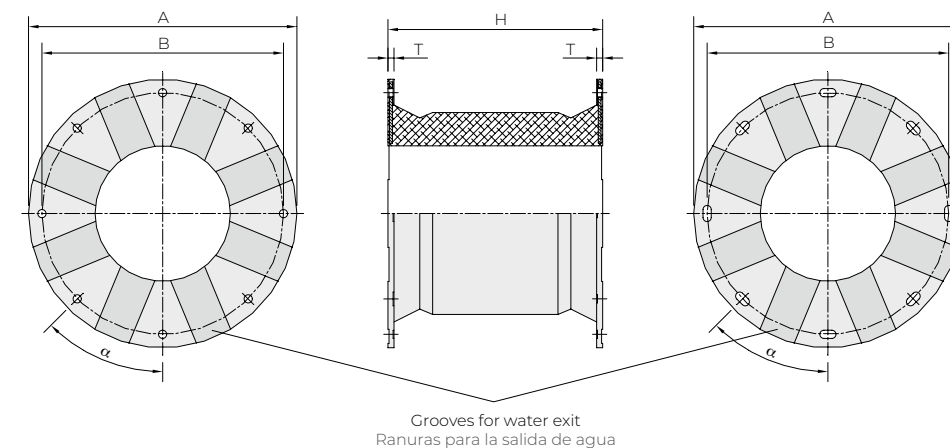

Fender Defensa []	H [mm]	ØA [mm]	ØB [mm]	T [mm]	Anchors Anclajes [n° x M]	α [°]	Weight Peso [kg]
SC-400	400	650	550	18	4xM22	90	62
SC-500	500	650	550	18	4xM22	90	86
SC-630	630	840	705	25	4xM30	90	173
SC-800	800	1050	900	30	6xM30	60	372
SC-1000	1000	1300	1100	35	6xM36	60	679
SC-1150	1150	1500	1300	37	6xM42	60	968
SC-1250	1250	1650	1450	40	6xM42	60	1317
SC-1450	1450	1850	1650	42	6xM48	60	2377
SC-1600	1600	2000	1800	45	8xM48	45	2538
SC-1700	1700	2100	1900	45	8xM56	45	3604
SC-2000	2000	2200	2000	50	8xM60	45	4798
SC-2250	2250	2550	2300	60	10xM64	36	6700
SC-2500	2500	2950	2700	70	10xM64	36	10020
SC-3000	3000	3350	3150	85	12xM76	30	16918

- See page 73 for different types of anchors / para diferentes tipos de anclajes ver página 73



SC TYPE FENDERS DEFENSAS TIPO SC

PERFORMANCE DATA / CARACTERÍSTICAS:

Size Tamaño	Grade Grado	E1	E2	E3	E4	E5	D1	D2	D3	D4	D5	C1	C2
SC-400	E [kNm] R [kN]	12,1 68,9	12,8 73,0	13,5 77,1	14,2 81,2	14,9 85,3	15,7 89,5	16,4 93,6	17,1 97,7	17,8 101,8	18,5 105,9	19,3 110,1	19,8 113,0
SC-500	E [kNm] R [kN]	22,6 103,0	23,9 109,1	25,3 115,7	26,8 122,3	28,2 128,9	29,7 135,5	30,8 140,6	32,0 146,3	33,2 151,4	34,4 157,1	35,5 162,3	36,8 167,9
SC-630	E [kNm] R [kN]	44,6 161,6	47,5 172,0	50,3 182,1	53,0 192,2	55,9 202,6	58,7 212,7	61,5 222,8	64,4 233,2	67,2 243,3	69,9 253,4	72,8 263,8	74,9 271,3
SC-800	E [kNm] R [kN]	87,7 250,4	93,5 267,2	99,4 284,0	105,3 300,8	111,0 317,2	116,9 334,0	122,5 349,9	128,1 366,1	133,7 382,0	139,4 398,2	144,9 414,1	149,7 427,6
SC-1000	E [kNm] R [kN]	176,5 404,0	187,6 429,2	198,7 454,7	209,7 479,9	220,8 505,3	231,9 530,6	243,0 556,0	254,0 581,2	265,1 606,7	276,1 631,9	287,3 657,4	295,8 676,9
SC-1150	E [kNm] R [kN]	265,2 527,3	281,8 560,3	298,4 593,2	315,1 626,4	331,7 659,4	348,2 692,3	364,9 725,5	381,5 758,5	398,1 791,4	414,8 824,6	431,4 857,6	444,3 883,4
SC-1250	E [kNm] R [kN]	338,8 619,3	360,1 658,3	381,4 697,3	402,6 736,1	423,9 775,0	445,3 814,0	466,4 852,6	487,4 891,0	508,5 929,6	529,5 968,0	550,6 1007	567,2 1037
SC-1450	E [kNm] R [kN]	525,4 828,7	558,2 880,4	591,0 932,2	623,8 983,9	656,5 1036	689,4 1087	722,1 1139	754,9 1191	787,6 1242	820,5 1294	853,3 1346	878,9 1386
SC-1600	E [kNm] R [kN]	706,2 1009	750,1 1097	794,2 1135	838,2 1197	882,2 1260	926,3 1323	970,3 1386	1014 1449	1058 1512	1102 1575	1146 1638	1181 1687
SC-1700	E [kNm] R [kN]	845,4 1138	898,4 1209	951,4 1281	1004 1352	1057 1423	1110 1494	1163 1566	1216 1637	1269 1708	1322 1780	1375 1851	1416 1906
SC-2000	E [kNm] R [kN]	1359 1553	1443 1650	1528 1747	1613 1844	1698 1940	1783 2037	1868 2135	1953 2232	2038 2329	2123 2426	2208 2523	2274 2599
SC-2250	E [kNm] R [kN]	2270 2307	2391 2430	2511 2552	2631 2674	2752 2797	2872 2919	2992 3041	3112 3163	3232 3285	3353 3407	3473 3529	3577 3635
SC-2500	E [kNm] R [kN]	3086 2823	3249 2973	3413 3122	3576 3272	3740 3421	3903 3571	4067 3721	4230 3870	4393 4019	4557 4169	4720 4318	4861 4448
SC-3000	E [kNm] R [kN]	4561 3476	4815 3670	5070 3864	5325 4058	5579 4252	5834 4446	6088 4640	6343 4834	6597 5029	6852 5223	7107 5417	7313 5574

- RPD (Rated Performance Data) values: impact velocity 150mm/s, temperature 23°C, impact angle 0°, for most common used rubber compound: blend of natural rubber (NR) and styrene-butadiene rubber (SBR)

- Valores RPD (Rated Performance Data): velocidad de impacto 150mm/s, temperatura 23°C, ángulo de impacto 0°, para el compuesto de caucho más usado: mezcla de caucho natural (NR) y caucho estireno-butadieno (SBR)

C3	C4	C5	B1	B2	B3	B4	B5	A1	A2	A3	A4	A5	Grade Grado	Size Tamaño
20,3 115,9	20,7 118,3	21,2 121,2	21,7 124,2	22,5 128,3	23,2 132,4	23,9 136,5	24,6 140,7	25,3 144,8	26,1 149,0	26,8 153,4	27,6 157,9	28,4 162,5	E [kNm] R [kN]	SC-400
37,9 173,1	39,1 178,7	40,3 183,9	41,5 189,5	42,4 193,8	43,4 198,0	44,3 202,2	45,2 206,5	46,2 211,2	47,3 216,0	48,4 220,9	49,5 225,9	50,6 231,1	E [kNm] R [kN]	SC-500
77,0 279,1	79,1 286,6	81,3 294,4	83,3 301,9	85,5 309,7	87,6 317,2	89,7 325,0	91,8 332,5	93,9 340,3	96,1 348,4	98,4 356,6	100,7 365,0	103,1 373,6	E [kNm] R [kN]	SC-630
154,3 440,8	159,0 454,4	163,7 467,6	168,3 480,9	172,8 493,8	177,3 506,5	181,7 519,1	186,1 531,8	190,6 544,4	195,1 557,4	199,7 570,6	204,5 584,2	209,3 598,1	E [kNm] R [kN]	SC-800
304,4 696,5	312,8 715,8	321,4 735,4	329,9 754,9	338,7 775,0	347,4 795,0	356,3 815,3	365,0 835,3	373,8 855,3	382,8 875,9	391,9 896,9	401,3 918,4	411,0 940,4	E [kNm] R [kN]	SC-1000
457,3 909,2	470,3 935,0	483,3 960,8	496,3 986,6	509,0 1012	521,7 1037	534,5 1063	547,2 1088	560,0 1113	573,1 1139	586,5 1166	600,1 1193	614,2 1221	E [kNm] R [kN]	SC-1150
583,7 1067	600,3 1097	616,8 1128	633,3 1158	650,1 1189	666,9 1219	683,6 1250	700,4 1280	717,2 1311	734,4 1343	752,0 1375	770,0 1408	788,5 1441	E [kNm] R [kN]	SC-1250
904,4 1427	930,1 1467	955,6 1507	981,3 1548	1007 1588	1033 1629	1058 1669	1084 1709	1109 1750	1135 1791	1162 1833	1190 1876	1218 1920	E [kNm] R [kN]	SC-1450
1215 1736	1249 1785	1284 1834	1318 1883	1352 1932	1387 1981	1421 2030	1456 2079	1490 2128	1525 2178	1561 2230	1598 2282	1635 2336	E [kNm] R [kN]	SC-1600
1458 1962	1499 2017	1540 2072	1581 2128	1622 2183	1663 2239	1705 2294	1746 2350	1787 2406	1830 2463	1873 2521	1917 2580	1963 2641	E [kNm] R [kN]	SC-1700
2340 2675	2407 2750	2473 2826	2539 2902	2605 2977	2671 3053	2738 3129	2804 3204	2870 3280	2938 3358	3007 3437	3078 3518	3151 3601	E [kNm] R [kN]	SC-2000
3681 3741	3786 3847	3890 3953	3994 4059	4098 4165	4202 4270	4306 4376	4410 4482	4514 4588	4621 4696	4730 4807	4841 4920	4955 5036	E [kNm] R [kN]	SC-2250
5003 4577	5144 4707	5286 4836	5427 4966	5569 5095	5710 5224	5852 5354	5993 5483	6135 5613	6280 5745	6428 5881	6579 6020	6735 6162	E [kNm] R [kN]	SC-2500
7519 5731	7726 5888	7932 6046	8138 6203	8345 6360	8551 6518	8758 6675	8964 6832	9170 6989	9381 7150	9597 7315	9818 7483	10044 7656	E [kNm] R [kN]	SC-3000

- RPD (Rated Performance Data) values: impact velocity 150mm/s, temperature 23°C, impact angle 0°, for most common used rubber compound: blend of natural rubber (NR) and styrene-butadiene rubber (SBR)

- Valores RPD (Rated Performance Data): velocidad de impacto 150mm/s, temperatura 23°C, ángulo de impacto 0°, para el compuesto de caucho más usado: mezcla de caucho natural (NR) y caucho estireno-butadieno (SBR)

CHARACTERISTIC PERFORMANCE CURVE / CURVA CARACTERÍSTICA DE RENDIMIENTO:

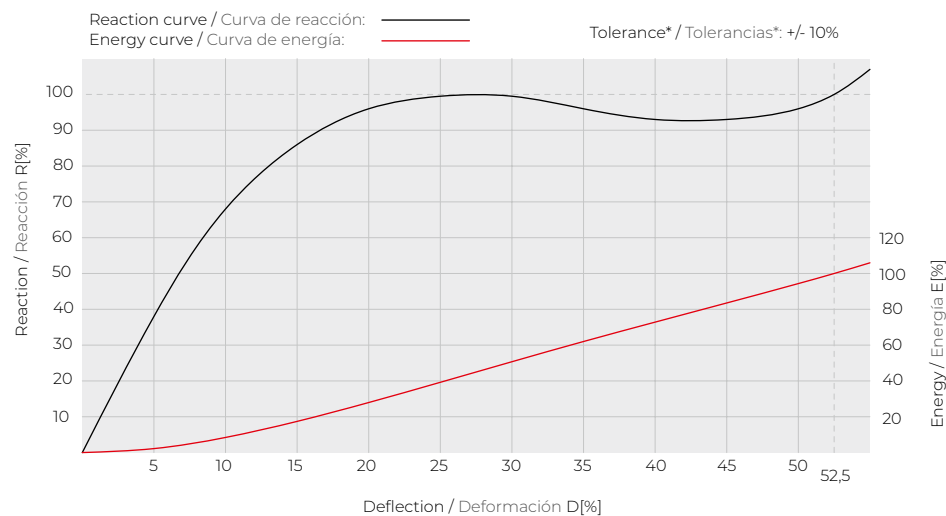

* Standard Reaction & Energy tolerances, tighter tolerances upon request

* Tolerancias de Reacción y Energía estándar, tolerancias más restrictivas bajo demanda

Reaction & Energy percentage values at intermediate Deflections Valores porcentuales de Reacción y Energía en Deformaciones intermedias													
Deflection / Deformación	D[%]	5	10	15	20	25	30	35	40	45	50	52,5	55
Reaction / Reacción	R[%]	38	68	86	96	99	99	96	93	93	96	100	107
Energy / Energía	E[%]	2	8	17	28	39	51	62	73	84	94	100	106

SC TYPE FENDERS DEFENSAS TIPO SC

CORRECTION FACTORS / FACTORES DE CORRECCIÓN:

Velocity correction factors* / Factores de corrección de velocidad*

VF	Impact Velocity / Velocidad de impacto											
	Size Tamaño	1 [mm/s]	25 [mm/s]	50 [mm/s]	100 [mm/s]	150 [mm/s]	200 [mm/s]	250 [mm/s]	300 [mm/s]	350 [mm/s]	400 [mm/s]	450 [mm/s]
SC-400	0,857	0,913	0,946	0,980	1	1,015	1,026	1,036	1,044	1,051	1,058	1,063
SC-500	0,867	0,913	0,946	0,980	1	1,015	1,026	1,036	1,044	1,051	1,058	1,063
SC-630	0,877	0,913	0,946	0,980	1	1,015	1,026	1,036	1,044	1,051	1,058	1,063
SC-800	0,888	0,913	0,946	0,980	1	1,015	1,026	1,036	1,044	1,051	1,058	1,063
SC-1000	0,898	0,913	0,946	0,980	1	1,015	1,026	1,036	1,044	1,051	1,058	1,063
SC-1150	0,904	0,913	0,946	0,980	1	1,015	1,026	1,036	1,044	1,051	1,058	1,063
SC-1250	0,908	0,913	0,946	0,980	1	1,015	1,026	1,036	1,044	1,051	1,058	1,063
SC-1450	0,915	0,915	0,946	0,980	1	1,015	1,026	1,036	1,044	1,051	1,058	1,063
SC-1600	0,920	0,920	0,946	0,980	1	1,015	1,026	1,036	1,044	1,051	1,058	1,063
SC-1700	0,922	0,922	0,946	0,980	1	1,015	1,026	1,036	1,044	1,051	1,058	1,063
SC-2000	0,930	0,930	0,946	0,980	1	1,015	1,026	1,036	1,044	1,051	1,058	1,063
SC-2250	0,936	0,936	0,946	0,980	1	1,015	1,026	1,036	1,044	1,051	1,058	1,063
SC-2500	0,941	0,941	0,946	0,980	1	1,015	1,026	1,036	1,044	1,051	1,058	1,063
SC-3000	0,950	0,950	0,950	0,980	1	1,015	1,026	1,036	1,044	1,051	1,058	1,063

Temperature correction factors* / Factores de corrección de temperatura*

Temperature [°C] Temperatura [°C]	-30	-20	-10	0	+10	+23	+30	+40	+50
TF	1,35	1,25	1,16	1,09	1,04	1	0,97	0,94	0,91

Angle correction factors* / Factores de corrección de ángulo*

Angle [°] Ángulo [°]	0	3	5	8	10	15	20
AF (Energy / Energía)	1	0,98	0,95	0,91	0,88	0,81	0,65
AF (Reaction / Reacción)	1	1	1	1	1	1	1

* Values for correction factors correspond to the most used rubber compound: blend of natural rubber (NR) and styrene-butadiene rubber (SBR)

* Los valores de los factores de corrección corresponden al compuesto de caucho más usado: mezcla de caucho natural (NR) y caucho estireno-butadieno (SBR)

INSTALLATION CLEARANCES / ESPACIO NECESARIO PARA LA INSTALACIÓN:

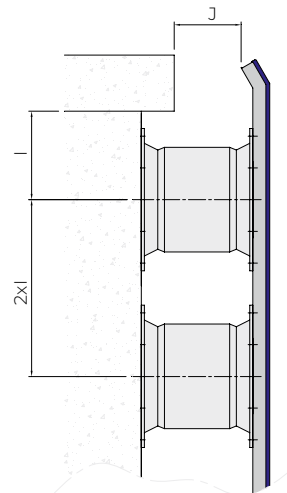

Size Tamaño	I [mm]	J [mm]
SC-400	370	240
SC-500	400	300
SC-630	450	380
SC-800	600	480
SC-1000	775	600
SC-1150	900	690
SC-1250	1000	750
SC-1450	1150	870
SC-1600	1250	960
SC-1700	1300	1020
SC-2000	1550	1200
SC-2250	1700	1350
SC-2500	1950	1500
SC-3000	2300	1800

WEIGHT SUPPORT CAPACITY / CAPACIDAD DE SOPORTAR PESO:

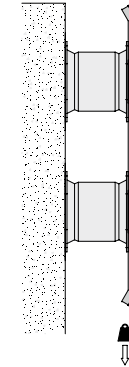
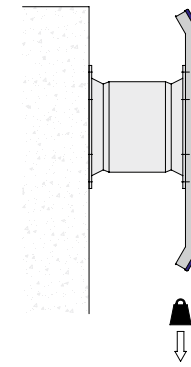

Single or multiple horizontal Una o varias horizontalmente	Grades / Grados				
	Size Tamaño []	E [kg]	D [kg]	C [kg]	B [kg]
SC-400	n x 62	n x 71	n x 81	n x 87	n x 93
SC-500	n x 86	n x 99	n x 112	n x 120	n x 129
SC-630	n x 173	n x 199	n x 225	n x 242	n x 260
SC-800	n x 372	n x 428	n x 484	n x 521	n x 558
SC-1000	n x 550	n x 750	n x 950	n x 1100	n x 1250
SC-1150	n x 681	n x 928	n x 1176	n x 1361	n x 1547
SC-1250	n x 819	n x 1116	n x 1414	n x 1637	n x 1861
SC-1450	n x 1167	n x 1591	n x 2015	n x 2334	n x 2652
SC-1600	n x 1214	n x 1655	n x 2096	n x 2427	n x 2758
SC-1700	n x 1498	n x 2043	n x 2587	n x 2996	n x 3404
SC-2000	n x 1778	n x 2425	n x 3072	n x 3557	n x 4042
SC-2250	n x 2173	n x 2963	n x 3753	n x 4346	n x 4938
SC-2500	n x 2776	n x 3772	n x 4778	n x 5533	n x 6287
SC-3000	n x 3788	n x 5165	n x 6543	n x 7576	n x 8609

n ≥ 1

Multiple vertical Varias verticalmente	Grades / Grados				
	Size Tamaño []	E [kg]	D [kg]	C [kg]	B [kg]
SC-400	n x 78	n x 93	n x 109	n x 124	n x 140
SC-500	n x 108	n x 129	n x 151	n x 172	n x 194
SC-630	n x 216	n x 260	n x 303	n x 346	n x 389
SC-800	n x 465	n x 558	n x 651	n x 744	n x 837
SC-1000	n x 688	n x 938	n x 1188	n x 1375	n x 1563
SC-1150	n x 851	n x 1160	n x 1470	n x 1702	n x 1934
SC-1250	n x 1023	n x 1396	n x 1768	n x 2047	n x 2326
SC-1450	n x 1459	n x 1989	n x 2519	n x 2917	n x 3315
SC-1600	n x 1517	n x 2069	n x 2620	n x 3034	n x 3448
SC-1700	n x 1872	n x 2553	n x 3234	n x 3745	n x 4255
SC-2000	n x 2223	n x 3031	n x 3840	n x 4446	n x 5052
SC-2250	n x 2716	n x 3704	n x 4691	n x 5432	n x 6173
SC-2500	n x 3458	n x 4715	n x 5973	n x 6916	n x 7859
SC-3000	n x 4735	n x 6457	n x 8178	n x 9470	n x 10761

n ≥ 2

DIMENSIONAL TOLERANCES / TOLERANCIAS DIMENSIONALES:

Dimension / Dimensión	Tolerances / Tolerancias
General dimensions / Dimensiones generales	±3% or 2mm* ±3% o 2mm*
Bolt holes spacing / Distancia entre agujeros de fijación	±4mm (non-cumulative) ±4mm (no-acumulativo)
Flange thickness / Espesor brida	±15mm
Bolt hole diameter / Diámetro agujeros de fijación	±5mm

* whichever is greater dimension

* la dimension mayor

IV TYPE FENDERS DEFENSAS TIPO IV

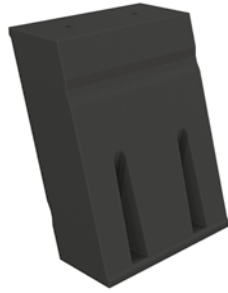

Features:

- High energy absorption
- Modular and compact design
- Symmetrical or asymmetrical installation
- Strong and durable
- Good in lengthwise shear
- Easy installation
- Wide range of sizes

Applications:

- All type of berths (coastal, river, tidal & non-tidal)
- All kind of berth structures (open, semi-open, closed, monopiles, dolphins)
- All types of terminals:
 - Oil and gas
 - Container
 - Bulk
 - General cargo
 - RoRo & cruise
 - Small crafts
- In parallel motion system
- Offshore platforms

Características:

- Alta capacidad de absorción de energía
- Diseño modular y compacto
- Instalación simétrica o asimétrica
- Robustas y duraderas
- Buena resistencia a esfuerzos longitudinales
- Instalación sencilla
- Gran rango de dimensiones

Aplicaciones:

- Todo tipo de atraques (costeros, fluviales, sometidos o no sometidos a mareas)
- Todo tipo de estructuras (abiertas, semi-abiertas, cerradas, monopilotes, duques de alba)
- Todo tipo de terminales:
 - Petroleo y gas
 - Contenedores
 - Granel
 - Carga general
 - RoRo y cruceros
 - Pequeñas embarcaciones
- Para sistemas de movimiento paralelo
- Plataformas offshore

DIMENSIONS / DIMENSIONES:

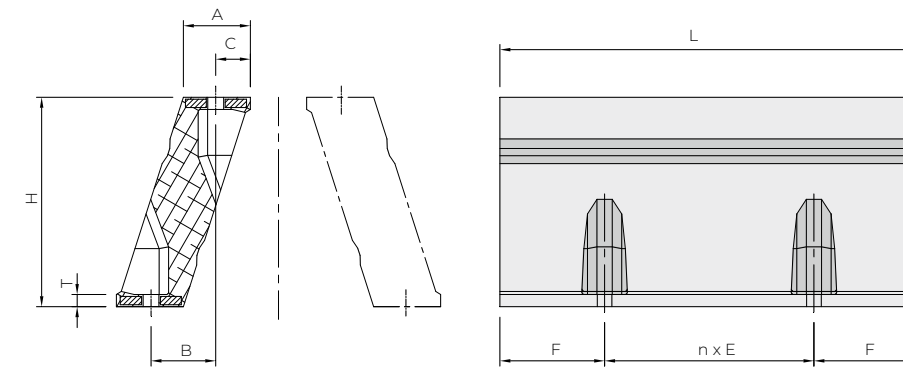

Fender Defensa	H	A	B	C	T	F	Anchors Anclajes	L = 1000mm		L = 1500mm		L = 2000mm	
								n x E	Weight Peso	n x E	Weight Peso	n x E	Weight Peso
[]	[mm]	[mm]	[mm]	[mm]	[mm]	[mm]	[Mnn]	[n x mm]	[kg]	[n x mm]	[kg]	[n x mm]	[kg]
IV-300	300	94	94	47	17	250	M20	1 x 500	45	2 x 500	66	3 x 500	90
IV-400	400	125	124	63	17	250	M24	1 x 500	70	2 x 500	105	3 x 500	140
IV-500	500	158	142	87	20	250	M30	1 x 500	110	2 x 500	165	3 x 500	220
IV-550	550	172	170	87	20	250	M30	1 x 500	132	2 x 500	195	3 x 500	265
IV-600	600	188	199	87	20	250	M30	1 x 500	155	2 x 500	230	3 x 500	310
IV-750	750	235	230	118	26	250	M36	1 x 500	240	2 x 500	350	3 x 500	480
IV-800	800	250	240	129	26	250	M36	1 x 500	270	2 x 500	405	3 x 500	540
IV-1000	1000	322	310	162	31	250	M42	1 x 500	435	2 x 500	650	3 x 500	870
IV-1250	1250	401	388	202	36	250	M48	1 x 500	640	2 x 500	960	3 x 500	1280
IV-1450	1450	454	445	228	41	250	M48	1 x 500	875	2 x 500	1310	3 x 500	1750
IV-1600	1600	500	480	257	50	250	M56	1 x 500	1010	2 x 500	1520	3 x 500	2020

- See page 73 for different types of anchors / para diferentes tipos de anclajes ver página 73

DIMENSIONAL TOLERANCES / TOLERANCIAS DIMENSIONALES:

Dimension / Dimensión	Tolerances / Tolerancias
General dimensions / Dimensiones generales	±3% or 2mm * ±3% o 2mm *
Bolt holes spacing / Distancia entre agujeros de fijación	±4mm (non-cumulative) ±4mm (no-acumulativo)
Flange thickness / Espesor brida	±15mm
Bolt hole diameter / Diámetro agujeros de fijación	±5mm

* whichever is greater dimension

* la dimension mayor



IV TYPE FENDERS DEFENSAS TIPO IV

PERFORMANCE DATA / CARACTERÍSTICAS:

Size Tamaño	Grade Grado	E1	E2	E3	E4	E5	D1	D2	D3	D4	D5	C1	C2
IV-300	E [kNm/m]	15,5	16,0	16,6	17,1	17,6	18,2	18,7	19,3	19,8	20,3	20,9	21,4
	R [kN/m]	112,3	116,2	120,1	124,0	127,8	131,7	135,6	139,5	143,4	147,3	151,2	155,1
IV-400	E [kNm/m]	27,2	28,2	29,1	30,1	31,0	31,9	32,9	33,8	34,8	35,7	36,7	37,6
	R [kN/m]	148,8	153,9	159,0	164,2	169,4	174,6	179,7	184,9	190,1	195,2	200,4	205,6
IV-500	E [kNm/m]	42,4	44,0	45,5	47,0	48,5	50,1	51,6	53,1	54,7	56,2	57,7	59,3
	R [kN/m]	185,3	191,9	198,6	205,3	212,0	218,7	225,4	232,1	238,7	245,4	252,1	258,8
IV-550	E [kNm/m]	51,6	53,4	55,3	57,1	58,9	60,7	62,5	64,4	66,2	68,0	69,8	71,6
	R [kN/m]	204,8	212,1	219,3	226,5	233,7	241,0	248,2	255,4	262,6	269,8	277,0	284,3
IV-600	E [kNm/m]	60,5	62,6	64,8	66,9	69,1	71,2	73,4	75,6	77,7	79,9	82,0	84,2
	R [kN/m]	219,9	227,8	235,6	243,4	251,3	259,1	266,9	274,7	282,6	290,4	298,2	306,0
IV-750	E [kNm/m]	93,3	96,6	99,8	103,0	106,2	109,5	112,7	115,9	119,2	122,4	125,6	128,8
	R [kN/m]	271,3	280,7	290,1	299,5	308,9	318,2	327,6	337,0	346,4	355,8	365,1	374,5
IV-800	E [kNm/m]	107,2	110,9	114,6	118,3	121,9	125,6	129,3	133,0	136,7	140,4	144,1	147,8
	R [kN/m]	292,1	302,1	312,2	322,2	332,3	342,3	352,4	362,4	372,5	382,5	392,6	402,6
IV-1000	E [kNm/m]	165,3	171,0	176,7	182,3	188,0	193,6	199,3	205,0	210,6	216,3	222,0	227,6
	R [kN/m]	360,2	372,5	384,9	397,2	409,5	421,9	434,2	446,6	458,9	471,2	483,6	495,9
IV-1250	E [kNm/m]	255,6	264,5	273,4	282,3	291,1	300,0	308,9	317,8	326,7	335,6	344,5	353,3
	R [kN/m]	446,1	461,6	477,1	492,6	508,1	523,6	539,1	554,6	570,1	585,6	601,2	616,7
IV-1450	E [kNm/m]	341,9	353,6	365,3	377,0	388,7	400,4	412,2	423,9	435,6	447,3	459,0	470,7
	R [kN/m]	514,1	531,7	549,3	567,0	584,6	602,2	619,8	637,4	655,0	672,6	690,2	707,8
IV-1600	E [kNm/m]	415,9	430,1	444,3	458,5	472,8	487,0	501,2	515,5	529,7	543,9	558,2	572,4
	R [kN/m]	566,6	585,9	605,3	624,7	644,1	663,5	682,9	702,3	721,6	741,0	760,4	779,8

- RPD (Rated Performance Data) values: impact velocity 150mm/s, temperature 23°C, impact angle 0°, for most common used rubber compound: blend of natural rubber (NR) and styrene-butadiene rubber (SBR)
- Valores RPD (Rated Performance Data): velocidad de impacto 150mm/s, temperatura 23°C, ángulo de impacto 0°, para el compuesto de caucho más usado: mezcla de caucho natural (NR) y caucho estireno-butadieno (SBR)
- All E and R values are for a single element of 1000mm length
- Los valores E y R corresponden a simple elemento de la longitud 1000mm

C3	C4	C5	B1	B2	B3	B4	B5	A1	A2	A3	A4	A5	Grade Grado	Size Tamaño
21,9 158,9	22,5 162,8	23,0 166,7	23,5 170,6	24,1 174,5	24,6 178,4	25,2 182,3	25,7 186,2	26,2 190,0	26,7 193,8	27,3 197,8	27,9 201,8	28,4 206,0	E [kNm/m] R [kN/m]	IV-300
38,6 210,8	39,5 215,9	40,5 221,1	41,4 226,3	42,4 231,5	43,3 236,6	44,2 241,8	45,2 247,0	46,1 251,9	47,0 257,0	48,0 262,2	48,9 267,4	49,9 272,8	E [kNm/m] R [kN/m]	IV-400
60,8 265,5	62,3 272,2	63,9 278,9	65,4 285,6	66,9 292,3	68,5 298,9	70,0 305,6	71,5 312,3	73,0 318,9	74,6 325,6	76,1 332,5	77,8 339,5	79,4 346,7	E [kNm/m] R [kN/m]	IV-500
73,5 291,5	75,3 298,7	77,1 305,9	78,9 313,1	80,7 320,3	82,5 327,6	84,4 334,8	86,2 342,0	88,0 349,3	89,9 356,8	91,8 364,4	93,8 372,2	95,8 380,2	E [kNm/m] R [kN/m]	IV-550
86,3 313,9	88,5 321,7	90,6 329,5	92,8 337,3	94,9 345,2	97,1 353,0	99,2 360,8	101,4 368,6	103,5 376,5	105,7 384,5	108,0 392,6	110,3 401,0	112,6 409,5	E [kNm/m] R [kN/m]	IV-600
132,1 383,9	135,3 393,3	138,5 402,7	141,7 412,0	145,0 421,4	148,2 430,8	151,4 440,2	154,6 449,6	157,9 459,0	161,2 468,6	164,6 478,5	168,1 488,5	171,6 498,8	E [kNm/m] R [kN/m]	IV-750
151,5 412,7	155,1 422,7	158,8 432,8	162,5 442,8	166,2 452,9	169,9 462,9	173,6 473,0	177,3 483,0	180,9 493,0	184,7 503,3	188,5 513,7	192,4 524,3	196,4 535,2	E [kNm/m] R [kN/m]	IV-800
233,3 508,2	238,9 520,6	244,6 532,9	250,3 545,2	255,9 557,6	261,6 569,9	267,3 582,2	272,9 594,6	278,6 606,9	284,3 619,4	290,2 632,3	296,2 645,4	302,3 658,7	E [kNm/m] R [kN/m]	IV-1000
362,2 632,2	371,1 647,7	380,0 663,2	388,9 678,7	397,8 694,2	406,7 709,7	415,6 725,2	424,4 740,7	433,3 756,2	442,3 772,0	451,6 788,1	461,0 804,5	470,6 821,3	E [kNm/m] R [kN/m]	IV-1250
482,4 725,5	494,1 743,1	505,8 760,7	517,6 778,3	529,3 795,9	541,0 813,5	552,7 831,1	564,4 848,7	576,1 866,3	588,0 884,3	600,2 902,6	612,7 921,3	625,4 940,4	E [kNm/m] R [kN/m]	IV-1450
586,6 799,2	600,8 818,6	615,1 838,0	629,3 857,4	643,5 876,8	657,8 896,1	672,0 915,5	686,2 934,9	700,4 954,3	714,9 974,0	729,7 994,2	744,8 1.015	760,2 1.036	E [kNm/m] R [kN/m]	IV-1600

- RPD (Rated Performance Data) values: impact velocity 150mm/s, temperature 23°C, impact angle 0°, for most common used rubber compound: blend of natural rubber (NR) and styrene-butadiene rubber (SBR)
- Valores RPD (Rated Performance Data): velocidad de impacto 150mm/s, temperatura 23°C, ángulo de impacto 0°, para el compuesto de caucho más usado: mezcla de caucho natural (NR) y caucho estireno-butadieno (SBR)
- All E and R values are for a single element of 1000mm length
- Los valores E y R corresponden a un elemento simple de longitud 1000mm

CHARACTERISTIC PERFORMANCE CURVE / CURVA CARACTERÍSTICA DE RENDIMIENTO:

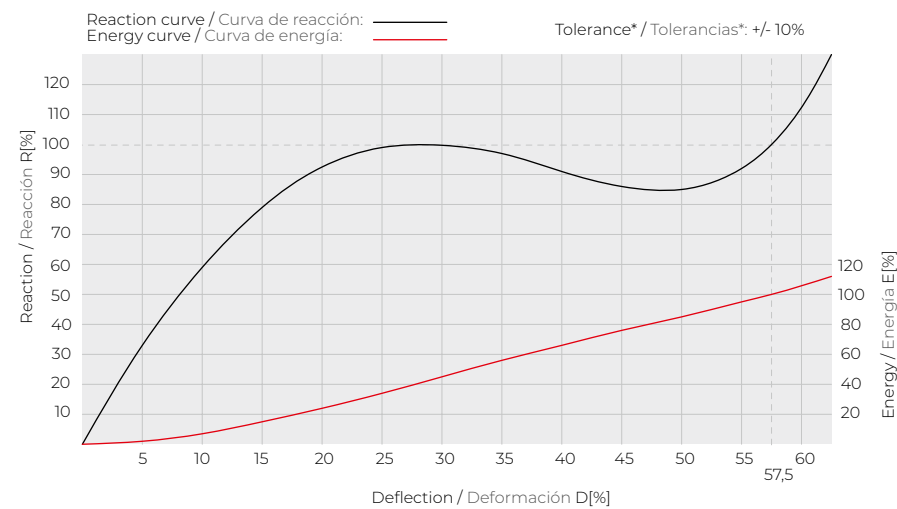

- * Standard Reaction & Energy tolerances, tighter tolerances upon request
- * Tolerancias de Reacción y Energía estándar, tolerancias más restrictivas bajo demanda

Reaction & Energy percentage values at intermediate Deflections Valores porcentuales de Reacción y Energía en Deformaciones intermedias														
Deflection / Deformación	D[%]	5	10	15	20	25	30	35	40	45	50	55	57,5	62,5
Reaction / Reacción	R[%]	33	59	79	92	99	100	97	91	86	85	92	100	130
Energy / Energía	E[%]	2	7	15	24	34	45	56	66	76	85	95	100	112

IV TYPE FENDERS DEFENSAS TIPO IV

CORRECTION FACTORS / FACTORES DE CORRECCIÓN:

Velocity correction factors* / Factores de corrección de velocidad*

VF	Impact Velocity / Velocidad de impacto											
	Size Tamaño	1 [mm/s]	25 [mm/s]	50 [mm/s]	100 [mm/s]	150 [mm/s]	200 [mm/s]	250 [mm/s]	300 [mm/s]	350 [mm/s]	400 [mm/s]	450 [mm/s]
IV-300	0,848	0,913	0,946	0,980	1	1,015	1,026	1,036	1,044	1,051	1,058	1,063
IV-400	0,861	0,913	0,946	0,980	1	1,015	1,026	1,036	1,044	1,051	1,058	1,063
IV-500	0,871	0,913	0,946	0,980	1	1,015	1,026	1,036	1,044	1,051	1,058	1,063
IV-550	0,875	0,913	0,946	0,980	1	1,015	1,026	1,036	1,044	1,051	1,058	1,063
IV-600	0,879	0,913	0,946	0,980	1	1,015	1,026	1,036	1,044	1,051	1,058	1,063
IV-750	0,889	0,913	0,946	0,980	1	1,015	1,026	1,036	1,044	1,051	1,058	1,063
IV-800	0,892	0,913	0,946	0,980	1	1,015	1,026	1,036	1,044	1,051	1,058	1,063
IV-1000	0,902	0,913	0,946	0,980	1	1,015	1,026	1,036	1,044	1,051	1,058	1,063
IV-1250	0,912	0,913	0,946	0,980	1	1,015	1,026	1,036	1,044	1,051	1,058	1,063
IV-1450	0,919	0,919	0,946	0,980	1	1,015	1,026	1,036	1,044	1,051	1,058	1,063
IV-1600	0,924	0,924	0,946	0,980	1	1,015	1,026	1,036	1,044	1,051	1,058	1,063

Temperature correction factors* / Factores de corrección de temperatura*

Temperature [°C] Temperatura [°C]	-30	-20	-10	0	+10	+23	+30	+40	+50
TF	1,35	1,25	1,16	1,09	1,04	1	0,97	0,94	0,91

Angle correction factors* / Factores de corrección de ángulo*

Angle [°] Ángulo [°]	0	3	5	8	10	15	20
AF (Energy / Energía)	1	0,97	0,95	0,92	0,90	0,84	0,79
AF (Reaction / Reacción)	1	1	1	1	1	1	1

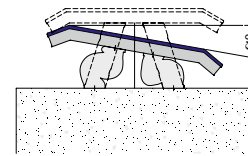

* Values for correction factors correspond to the most used rubber compound: blend of natural rubber (NR) and styrene-butadiene rubber (SBR)
* Los valores de los factores de corrección corresponden al compuesto de caucho más usado: mezcla de caucho natural (NR) y caucho estireno-butadieno (SBR)

INSTALLATION CLEARANCES / ESPACIO NECESARIO PARA LA INSTALACIÓN:

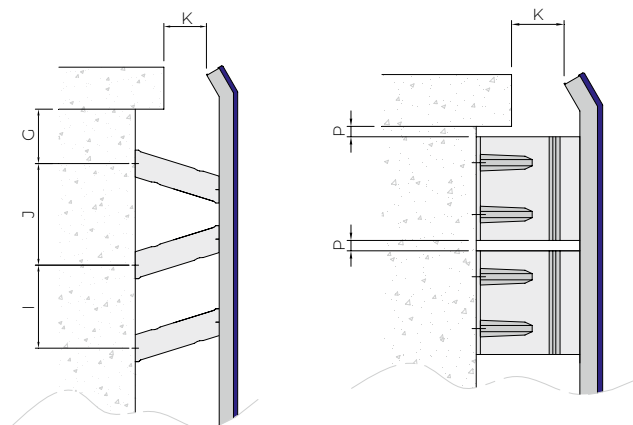

Size Tamaño	G [mm]	J [mm]	I [mm]	K [mm]	P [mm]
IV-300	75	370	235	210	≥100
IV-400	100	485	315	280	≥100
IV-500	120	610	390	350	≥100
IV-550	135	670	430	385	≥100
IV-600	145	730	470	420	≥100
IV-750	180	910	585	525	≥100
IV-800	195	1000	625	560	≥100
IV-1000	240	1210	780	700	≥100
IV-1250	300	1520	975	875	≥100
IV-1450	350	1710	1130	1015	≥100
IV-1600	385	1840	1250	1120	≥100

WEIGHT SUPPORT CAPACITY / CAPACIDAD DE SOPORTAR PESO:

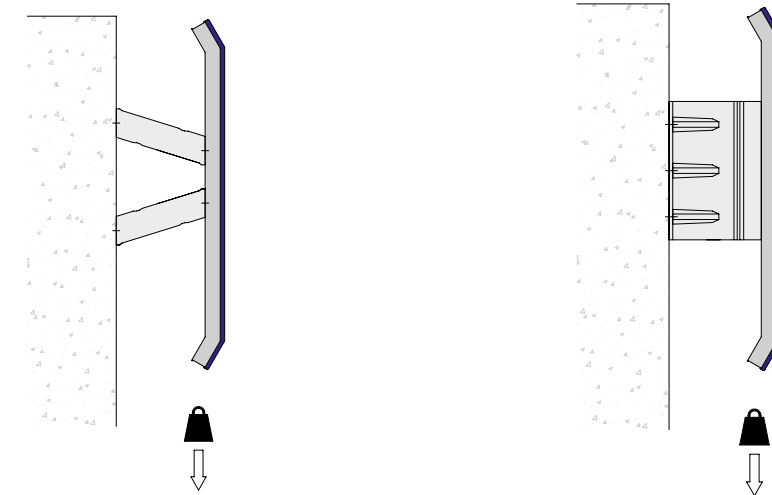

Horizontal		Grades / Grados					Vertical		Grades / Grados				
Size Tamaño []	Length Longitud [mm]	E [kg]	D [kg]	C [kg]	B [kg]	A [kg]	Size Tamaño []	Length Longitud [mm]	E [kg]	D [kg]	C [kg]	B [kg]	A [kg]
IV-300	1000	n x 210	n x 248	n x 285	n x 323	n x 360	IV-300	1000	n x 360	n x 435	n x 510	n x 585	n x 660
	1500	n x 315	n x 371	n x 428	n x 484	n x 540		1500	n x 540	n x 653	n x 765	n x 878	n x 990
	2000	n x 420	n x 495	n x 570	n x 645	n x 720		2000	n x 720	n x 870	n x 1020	n x 1170	n x 1320
IV-400	1000	n x 280	n x 330	n x 380	n x 430	n x 480	IV-400	1000	n x 480	n x 580	n x 680	n x 780	n x 880
	1500	n x 420	n x 495	n x 570	n x 645	n x 720		1500	n x 720	n x 870	n x 1020	n x 1170	n x 1320
	2000	n x 560	n x 660	n x 760	n x 860	n x 960		2000	n x 960	n x 1160	n x 1360	n x 1560	n x 1760
IV-500	1000	n x 350	n x 413	n x 475	n x 538	n x 600	IV-500	1000	n x 600	n x 725	n x 850	n x 975	n x 1100
	1500	n x 525	n x 619	n x 713	n x 806	n x 900		1500	n x 900	n x 1088	n x 1275	n x 1463	n x 1650
	2000	n x 700	n x 825	n x 950	n x 1075	n x 1200		2000	n x 1200	n x 1450	n x 1700	n x 1950	n x 2200
IV-550	1000	n x 385	n x 454	n x 523	n x 591	n x 660	IV-550	1000	n x 660	n x 798	n x 935	n x 1073	n x 1210
	1500	n x 578	n x 681	n x 784	n x 887	n x 990		1500	n x 990	n x 1196	n x 1403	n x 1609	n x 1815
	2000	n x 770	n x 908	n x 1045	n x 1183	n x 1320		2000	n x 1320	n x 1595	n x 1870	n x 2145	n x 2420
IV-600	1000	n x 420	n x 495	n x 570	n x 645	n x 720	IV-600	1000	n x 720	n x 870	n x 1020	n x 1170	n x 1320
	1500	n x 630	n x 743	n x 855	n x 968	n x 1080		1500	n x 1080	n x 1305	n x 1530	n x 1755	n x 1980
	2000	n x 840	n x 990	n x 1140	n x 1290	n x 1440		2000	n x 1440	n x 1740	n x 2040	n x 2340	n x 2640
IV-750	1000	n x 525	n x 619	n x 713	n x 806	n x 900	IV-750	1000	n x 900	n x 1088	n x 1275	n x 1463	n x 1650
	1500	n x 788	n x 928	n x 1069	n x 1209	n x 1350		1500	n x 1350	n x 1631	n x 1913	n x 2194	n x 2475
	2000	n x 1050	n x 1238	n x 1425	n x 1613	n x 1800		2000	n x 1800	n x 2175	n x 2550	n x 2925	n x 3300
IV-800	1000	n x 560	n x 660	n x 760	n x 860	n x 960	IV-800	1000	n x 960	n x 1160	n x 1360	n x 1560	n x 1760
	1500	n x 840	n x 990	n x 1140	n x 1290	n x 1440		1500	n x 1440	n x 1740	n x 2040	n x 2340	n x 2640
	2000	n x 1120	n x 1320	n x 1520	n x 1720	n x 1920		2000	n x 1920	n x 2320	n x 2720	n x 3120	n x 3520
IV-1000	1000	n x 700	n x 825	n x 950	n x 1075	n x 1200	IV-1000	1000	n x 1200	n x 1450	n x 1700	n x 1950	n x 2200
	1500	n x 1050	n x 1238	n x 1425	n x 1613	n x 1800		1500	n x 1800	n x 2175	n x 2550	n x 2925	n x 3300
	2000	n x 1400	n x 1650	n x 1900	n x 2150	n x 2400		2000	n x 2400	n x 2900	n x 3400	n x 3900	n x 4400
IV-1250	1000	n x 875	n x 1031	n x 1188	n x 1344	n x 1500	IV-1250	1000	n x 1500	n x 1813	n x 2125	n x 2438	n x 2750
	1500	n x 1313	n x 1547	n x 1781	n x 2016	n x 2250		1500	n x 2250	n x 2719	n x 3188	n x 3656	n x 4125
	2000	n x 1750	n x 2063	n x 2375	n x 2688	n x 3000		2000	n x 3000	n x 3625	n x 4250	n x 4875	n x 5500
IV-1450	1000	n x 1015	n x 1196	n x 1378	n x 1559	n x 1740	IV-1450	1000	n x 1740	n x 2103	n x 2465	n x 2828	n x 3190
	1500	n x 1523	n x 1794	n x 2066	n x 2338	n x 2610		1500	n x 2610	n x 3154	n x 3698	n x 4241	n x 4785
	2000	n x 2030	n x 2393	n x 2755	n x 3118	n x 3480		2000	n x 3480	n x 4205	n x 4930	n x 5655	n x 6380
IV-1600	1000	n x 1120	n x 1320	n x 1520	n x 1720	n x 1920	IV-1600	1000	n x 1920	n x 2320	n x 2720	n x 3120	n x 3520
	1500	n x 1680	n x 1980	n x 2280	n x 2580	n x 2880		1500	n x 2880	n x 3480	n x 4080	n x 4680	n x 5280
	2000	n x 2240	n x 2640	n x 3040	n x 3440	n x 3840		2000	n x 3840	n x 4640	n x 5440	n x 6240	n x 7040

n - is number of pair of elements
n - es el número de pares de elementos

n - is number of pair of elements
n - es el número de pares de elementos

SVA TYPE FENDERS

DEFENSAS TIPO SVA



Features:

- One-piece design
- Strong and durable
- Good shear performance in longitudinal direction
- Wide range of standard sizes
- Easy installation
- Horizontal or vertical installation
- Minimum maintenance

Applications:

- All type of berths (coastal, river)
- Multi-purpose terminals
- General cargo berths
- Barge and tug berths
- Fishing boat berths

Características:

- Diseño de una pieza
- Robustas y duraderas
- Buenas características angulares en dirección longitudinal
- Gran rango de dimensiones estándar
- Instalación sencilla
- Instalación en horizontal o vertical
- Mantenimiento mínimo

Aplicaciones:

- Todos los tipos de atraques (costeros, fluviales)
- Terminales multi uso
- Muelles de carga general
- Muelles para barcasas y remolcadores
- Muelles de pesqueros



DIMENSIONS / DIMENSIONES:

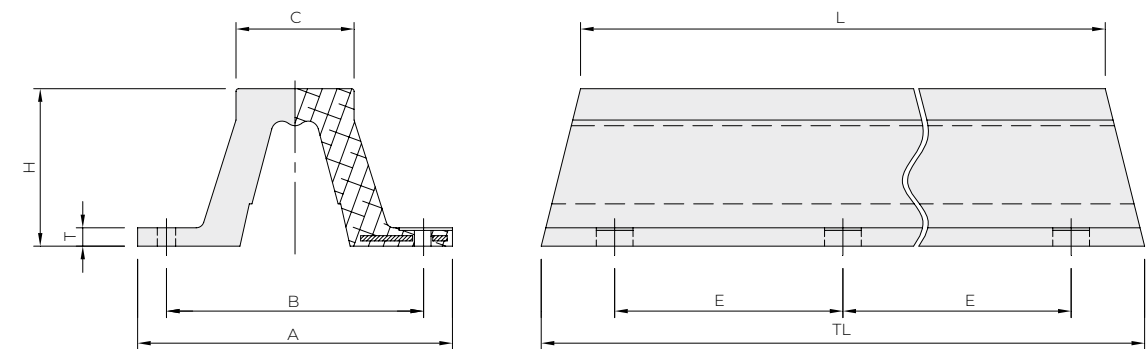

Fender Defensa []	H [mm]	A [mm]	B [mm]	C [mm]	T [mm]	Anchors Anclajes [M]	Weight Peso [kg/m]
SVA-150	150	300	240	98	25	M20	37
SVA-200	200	400	320	130	30	M24	62
SVA-250	250	500	410	165	33	M24	90
SVA-300	300	600	490	225	35	M30	125
SVA-400	400	800	670	300	40	M36	210
SVA-500	500	1000	840	375	45	M42	330
SVA-600	600	1200	1010	450	55	M48	480
SVA-800	800	1600	1340	600	70	M56	880
SVA-1000	1000	2000	1680	750	90	M56	1400

- See page 73 for different types of anchors / para diferentes tipos de anclajes ver página 73

Fender Defensa	L = 1000mm			L = 1500mm			L = 2000mm			L = 2500mm			L = 3000mm			L = 3500mm		
	TL [mm]	n []	E [mm]	TL [mm]	n []	E [mm]	TL [mm]	n []	E [mm]	TL [mm]	n []	E [mm]	TL [mm]	n []	E [mm]	TL [mm]	n []	E [mm]
SVA-150	1075	4	855	1575	6	675	2075	8	620	2575	8	785	3075	10	715	3575	12	671
SVA-200	1100	4	860	1600	6	680	2100	8	620	2600	8	785	3100	10	715	3600	12	672
SVA-250	1125	4	865	1625	6	680	2125	8	620	2625	8	790	3125	10	715	3625	12	673
SVA-300	1150	4	870	1650	6	685	2150	8	625	2650	8	790	3150	10	715	3650	12	674
SVA-400	1200	4	900	1700	6	700	2200	8	635	2700	8	800	3200	10	725	3700	12	680
SVA-500	1250	4	930	1750	6	715	2250	8	645	2750	8	810	3250	10	730	3750	12	686
SVA-600	1300	4	960	1800	6	730	2300	8	655	2800	8	820	3300	10	740	3800	12	692
SVA-800	1400	4	1040	1900	6	770	2400	8	680	2900	8	845	3400	10	760	3900	12	708
SVA-1000	1500	4	1100	2000	6	800	2500	8	700	3000	8	865	3500	10	775	4000	12	720

n - number of anchors / n - número de anclajes

SVA TYPE FENDERS

DEFENSAS TIPO SVA

PERFORMANCE DATA / CARACTERÍSTICAS:

Size Tamaño	Grade Grado	E1	E2	E3	E4	E5	D1	D2	D3	D4	D5	C1	C2
SVA-150	E [kNm/m] R [kN/m]	6,1 98,7	6,4 102,7	6,6 106,8	6,9 111,0	7,2 115,5	7,4 120,1	7,6 123,0	7,9 127,2	8,1 130,1	8,3 134,4	8,5 137,3	8,7 140,1
SVA-200	E [kNm/m] R [kN/m]	12,2 149,3	12,8 155,5	13,3 161,7	13,7 166,7	14,2 172,9	14,7 179,1	15,2 185,3	15,7 191,6	16,1 196,5	16,6 202,8	17,1 209,0	17,6 215,2
SVA-250	E [kNm/m] R [kN/m]	18,3 177,3	19,0 184,2	19,7 191,1	20,4 198,1	21,1 205,0	21,8 211,9	22,5 218,9	23,3 225,8	24,1 233,7	24,8 240,6	25,5 247,6	26,0 252,5
SVA-300	E [kNm/m] R [kN/m]	26,5 215,6	27,4 223,1	28,4 230,5	29,4 238,8	30,3 246,3	31,3 254,6	32,5 264,5	33,7 273,7	34,9 283,6	36,1 293,6	37,3 303,5	38,3 311,0
SVA-400	E [kNm/m] R [kN/m]	45,4 276,8	47,2 288,0	49,2 299,8	51,1 311,6	52,9 322,8	54,9 334,6	56,8 346,4	58,8 358,2	60,6 369,4	62,5 381,3	64,5 393,1	66,4 404,9
SVA-500	E [kNm/m] R [kN/m]	70,7 344,8	73,7 359,7	76,8 374,7	79,9 389,6	82,9 404,5	86,0 419,4	88,8 433,4	91,7 447,3	94,5 460,7	97,3 474,7	100,2 488,6	103,2 503,5
SVA-600	E [kNm/m] R [kN/m]	100,9 410,1	105,1 427,1	109,3 444,5	113,5 461,5	117,8 478,9	122,0 495,9	126,2 512,9	130,5 530,3	134,6 547,3	138,9 564,7	143,1 581,7	147,3 598,7
SVA-800	E [kNm/m] R [kN/m]	178,3 543,6	185,7 566,3	193,1 588,7	200,5 611,4	207,9 633,8	215,3 656,5	222,8 679,2	230,1 701,6	237,6 724,3	245,0 747,0	252,3 769,4	259,8 792,1
SVA-1000	E [kNm/m] R [kN/m]	274,2 668,7	285,6 696,6	297,0 724,4	308,4 752,3	319,9 780,2	331,3 808,0	342,7 835,9	354,1 863,8	365,6 891,6	377,0 919,5	388,4 947,4	399,8 975,2

- RPD (Rated Performance Data) values: impact velocity 150mm/s, temperature 23°C, impact angle 0°, for most common used rubber compound: blend of natural rubber (NR) and styrene-butadiene rubber (SBR)

- Valores RPD (Rated Performance Data): velocidad de impacto 150mm/s, temperatura 23°C, ángulo de impacto 0°, para el compuesto de caucho más usado: mezcla de caucho natural (NR) y caucho estireno-butadieno (SBR)

C3	C4	C5	B1	B2	B3	B4	B5	A1	A2	A3	A4	A5	Grade Grado	Size Tamaño
9,0 144,4	9,1 147,3	9,4 151,5	9,6 154,4	9,8 157,3	10,0 161,6	10,2 164,4	10,5 168,7	10,6 171,6	10,8 174,5	11,0 177,4	11,2 180,4	11,4 183,5	E [kNm/m] R [kN/m]	SVA-150
18,2 221,4	18,6 226,4	19,1 232,6	19,6 238,8	20,1 245,0	20,6 251,3	21,0 256,2	21,5 262,5	22,0 268,7	22,6 275,0	23,1 281,6	23,6 288,2	24,2 295,1	E [kNm/m] R [kN/m]	SVA-200
26,4 256,5	26,9 261,4	27,4 266,4	27,9 271,3	28,6 277,3	29,3 284,2	30,0 291,1	30,7 298,1	31,4 305,0	32,1 312,1	32,9 319,4	33,7 326,8	34,4 334,4	E [kNm/m] R [kN/m]	SVA-250
39,3 319,3	40,2 326,7	41,2 335,0	42,1 342,5	43,4 352,4	44,6 362,4	45,7 371,5	46,9 381,5	48,1 391,4	49,4 401,6	50,7 412,1	52,0 422,9	53,4 433,9	E [kNm/m] R [kN/m]	SVA-300
68,2 416,1	70,2 427,9	72,1 439,7	74,0 450,9	75,9 462,7	77,8 474,5	79,8 486,4	81,6 497,6	83,5 509,4	85,5 521,5	87,6 533,9	89,6 546,5	91,8 559,5	E [kNm/m] R [kN/m]	SVA-400
106,3 518,5	109,3 533,4	112,4 548,3	115,5 563,2	118,3 577,2	121,1 590,6	123,9 604,5	126,8 618,5	129,6 632,4	132,6 646,6	135,5 661,2	138,6 676,1	141,7 691,3	E [kNm/m] R [kN/m]	SVA-500
151,6 616,1	155,8 633,1	160,0 650,6	164,2 667,6	168,4 684,6	172,7 702,0	176,9 719,0	181,2 736,4	185,3 753,4	189,6 770,8	194,0 788,6	198,5 806,8	203,0 825,4	E [kNm/m] R [kN/m]	SVA-600
267,2 814,8	274,6 837,1	282,0 859,8	289,5 882,5	296,8 904,9	304,3 927,6	311,6 950,0	319,1 972,7	326,5 995,4	334,1 1019	341,9 1042	349,9 1067	358,1 1092	E [kNm/m] R [kN/m]	SVA-800
411,3 1003	422,7 1031	434,1 1059	445,5 1087	457,0 1115	468,4 1142	479,8 1170	491,2 1198	502,7 1226	514,3 1255	526,3 1284	538,5 1314	551,1 1344	E [kNm/m] R [kN/m]	SVA-1000

- RPD (Rated Performance Data) values: impact velocity 150mm/s, temperature 23°C, impact angle 0°, for most common used rubber compound: blend of natural rubber (NR) and styrene-butadiene rubber (SBR)

- Valores RPD (Rated Performance Data): velocidad de impacto 150mm/s, temperatura 23°C, ángulo de impacto 0°, para el compuesto de caucho más usado: mezcla de caucho natural (NR) y caucho estireno-butadieno (SBR)

CHARACTERISTIC PERFORMANCE CURVE / CURVA CARACTERÍSTICA DE RENDIMIENTO:

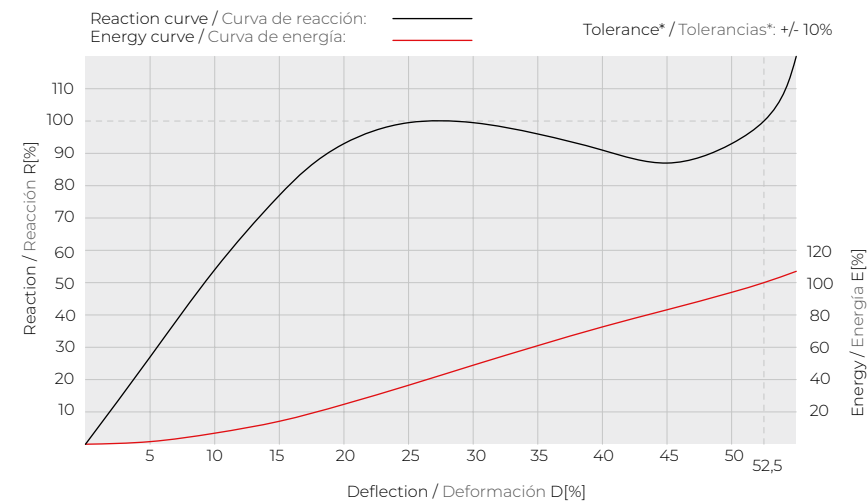

* Standard Reaction & Energy tolerances, tighter tolerances upon request

* Tolerancias de Reacción y Energía estándar, tolerancias más restrictivas bajo demanda

Reaction & Energy percentage values at intermediate Deflections Valores porcentuales de Reacción y Energía en Deformaciones intermedias													
Deflection / Deformación	D[%]	5	10	15	20	25	30	35	40	45	50	52,5	55
Reaction / Reacción	R[%]	27	54	77	93	99	100	96	91	87	93	100	120
Energy / Energía	E[%]	2	7	14	25	37	49	61	72	83	94	100	107

CORRECTION FACTORS / FACTORES DE CORRECCIÓN:

Velocity correction factors* / Factores de corrección de velocidad*

VF	Impact Velocity / Velocidad de impacto											
	1 [mm/s]	25 [mm/s]	50 [mm/s]	100 [mm/s]	150 [mm/s]	200 [mm/s]	250 [mm/s]	300 [mm/s]	350 [mm/s]	400 [mm/s]	450 [mm/s]	500 [mm/s]
SVA-150	0,815	0,913	0,946	0,980	1	1,015	1,026	1,036	1,044	1,051	1,058	1,063
SVA-200	0,827	0,913	0,946	0,980	1	1,015	1,026	1,036	1,044	1,051	1,058	1,063
SVA-250	0,837	0,913	0,946	0,980	1	1,015	1,026	1,036	1,044	1,051	1,058	1,063
SVA-300	0,844	0,913	0,946	0,980	1	1,015	1,026	1,036	1,044	1,051	1,058	1,063
SVA-400	0,857	0,913	0,946	0,980	1	1,015	1,026	1,036	1,044	1,051	1,058	1,063
SVA-500	0,867	0,913	0,946	0,980	1	1,015	1,026	1,036	1,044	1,051	1,058	1,063
SVA-600	0,875	0,913	0,946	0,980	1	1,015	1,026	1,036	1,044	1,051	1,058	1,063
SVA-800	0,888	0,913	0,946	0,980	1	1,015	1,026	1,036	1,044	1,051	1,058	1,063
SVA-1000	0,898	0,913	0,946	0,980	1	1,015	1,026	1,036	1,044	1,051	1,058	1,063

Temperature correction factors* / Factores de corrección de temperatura*

Temperature [°C] Temperatura [°C]	-30	-20	-10	0	+10	+23	+30	+40	+50
TF	1,35	1,25	1,16	1,09	1,04	1	0,97	0,94	0,91

Angle correction factors* / Factores de corrección de ángulo*

Angle [°] Ángulo [°]	0	3	5	8	10	15	20
AF (Energy / Energía)	1	0,98	0,97	0,95	0,92	0,84	0,77
AF (Reaction / Reacción)	1	1	1	1	1	1	1

* Values for correction factors correspond to the most used rubber compound: blend of natural rubber (NR) and styrene-butadiene rubber (SBR)

* Los valores de los factores de corrección corresponden al compuesto de caucho más usado: mezcla de caucho natural (NR) y caucho estireno-butadieno (SBR)

SVA-P TYPE FENDERS

DEFENSAS TIPO SVA-P



Features:

- One-piece design
- Strong and durable
- Good shear performance in longitudinal direction
- Wide range of standard sizes
- Easy installation
- Horizontal or vertical installation
- Minimum maintenance

Applications:

- All kind of berths (coastal, river)
- Multi-purpose terminals
- General cargo berths
- Fishing boat berths
- Barge and tug berths

Características:

- Diseño de una pieza
- Robustas y duraderas
- Buenas características angulares en dirección longitudinal
- Gran rango de dimensiones estándar
- Instalación sencilla
- Instalación en horizontal o vertical
- Mantenimiento mínimo

Aplicaciones:

- Todos los tipos de atraques (costeros, fluviales)
- Terminales multi uso
- Muelles de carga general
- Muelles de pesqueros
- Muelles para barcasas y remolcadores

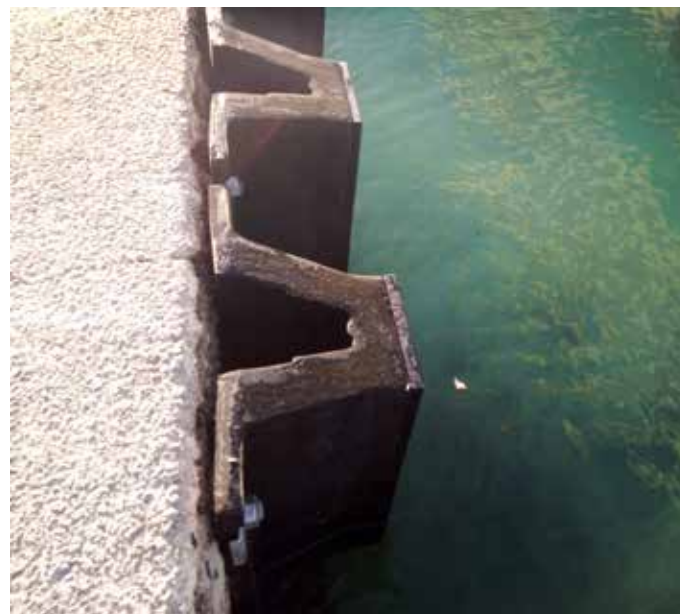

DIMENSIONS / DIMENSIONES:

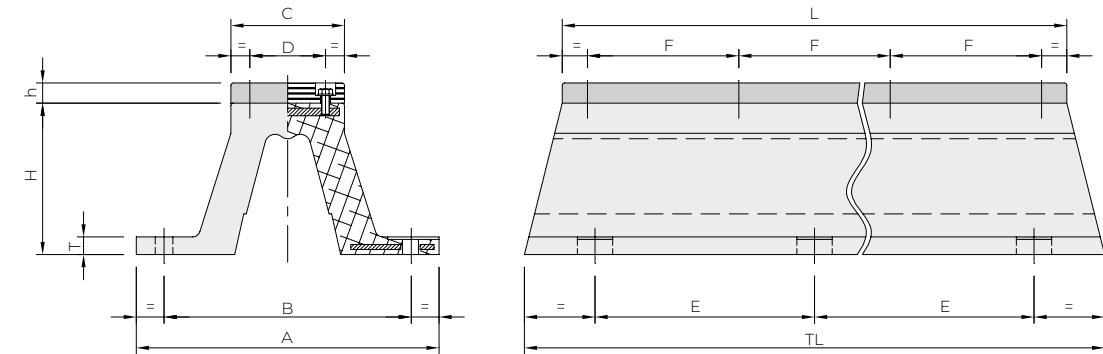

Fender Defensa	Reinforced Rubber Unit / Unidad de caucho reforzado						UHMW-PE Pad / Placa PE-UAPM				Total weight Peso total
	H [mm]	A [mm]	B [mm]	C [mm]	T [mm]	Anchors Anclajes [Mnn]	h [mm]	Bolts Tornillos [Mnn]	D [mm]	F [mm]	
SVA-P-150	150	300	240	98	25	M20	30	M16	0	295-375	42
SVA-P-200	200	400	320	130	30	M24	30	M16	80	295-375	68
SVA-P-250	250	500	410	165	33	M24	30	M16	110	295-375	98
SVA-P-300	300	600	490	225	35	M30	40	M16	165	295-375	135
SVA-P-400	400	800	670	300	40	M36	40	M20	200	295-375	225
SVA-P-500	500	1000	840	375	45	M42	50	M20	275	295-375	355
SVA-P-600	600	1200	1010	450	55	M48	50	M20	350	295-375	510
SVA-P-800	800	1600	1340	600	70	M56	60	M24	470	295-375	920
SVA-P-1000	1000	2000	1680	750	90	M56	60	M24	620	295-375	1450

- See page 73 for different types of anchors / para diferentes tipos de anclajes ver página 73

Fender/ Defensa	L = 1000mm			L = 1500mm			L = 2000mm			L = 2500mm			L = 3000mm			L = 3500mm		
	TL [mm]	n []	E [mm]	TL [mm]	n []	E [mm]	TL [mm]	n []	E [mm]	TL [mm]	n []	E [mm]	TL [mm]	n []	E [mm]	TL [mm]	n []	E [mm]
SVA-P-150	1075	4	855	1575	6	675	2075	8	620	2575	8	785	3075	10	715	3575	12	671
SVA-P-200	1100	4	860	1600	6	680	2100	8	620	2600	8	785	3100	10	715	3600	12	672
SVA-P-250	1125	4	865	1625	6	680	2125	8	620	2625	8	790	3125	10	715	3625	12	673
SVA-P-300	1150	4	870	1650	6	685	2150	8	625	2650	8	790	3150	10	715	3650	12	674
SVA-P-400	1200	4	900	1700	6	700	2200	8	635	2700	8	800	3200	10	725	3700	12	680
SVA-P-500	1250	4	930	1750	6	715	2250	8	645	2750	8	810	3250	10	730	3750	12	686
SVA-P-600	1300	4	960	1800	6	730	2300	8	655	2800	8	820	3300	10	740	3800	12	692
SVA-P-800	1400	4	1040	1900	6	770	2400	8	680	2900	8	845	3400	10	760	3900	12	708
SVA-P-1000	1500	4	1100	2000	6	800	2500	8	700	3000	8	865	3500	10	775	4000	12	720

n - number of anchors / n - número de anclajes

SVA-P TYPE FENDERS

DEFENSAS TIPO SVA-P

PERFORMANCE DATA / CARACTERÍSTICAS:

Size Tamaño	Grade Grado	E1	E2	E3	E4	E5	D1	D2	D3	D4	D5	C1	C2
SVA-P-150	E [kNm/m] R [kN/m]	6,1 98,7	6,4 102,7	6,6 106,8	6,9 111,0	7,2 115,5	7,4 120,1	7,6 123,0	7,9 127,2	8,1 130,1	8,3 134,4	8,5 137,3	8,7 140,1
SVA-P-200	E [kNm/m] R [kN/m]	12,2 149,3	12,8 155,5	13,3 161,7	13,7 166,7	14,2 172,9	14,7 179,1	15,2 185,3	15,7 191,6	16,1 196,5	16,6 202,8	17,1 209,0	17,6 215,2
SVA-P-250	E [kNm/m] R [kN/m]	18,3 177,3	19,0 184,2	19,7 191,1	20,4 198,1	21,1 205,0	21,8 211,9	22,5 218,9	23,3 225,8	24,1 233,7	24,8 240,6	25,5 247,6	26,0 252,5
SVA-P-300	E [kNm/m] R [kN/m]	26,5 215,6	27,4 223,1	28,4 230,5	29,4 238,8	30,3 246,3	31,3 254,6	32,5 264,5	33,7 273,7	34,9 283,6	36,1 293,6	37,3 303,5	38,3 311,0
SVA-P-400	E [kNm/m] R [kN/m]	45,4 276,8	47,2 288,0	49,2 299,8	51,1 311,6	52,9 322,8	54,9 334,6	56,8 346,4	58,8 358,2	60,6 369,4	62,5 381,3	64,5 393,1	66,4 404,9
SVA-P-500	E [kNm/m] R [kN/m]	70,7 344,8	73,7 359,7	76,8 374,7	79,9 389,6	82,9 404,5	86,0 419,4	88,8 433,4	91,7 447,3	94,5 460,7	97,3 474,7	100,2 488,6	103,2 503,5
SVA-P-600	E [kNm/m] R [kN/m]	100,9 410,1	105,1 427,1	109,3 444,5	113,5 461,5	117,8 478,9	122,0 495,9	126,2 512,9	130,5 530,3	134,6 547,3	138,9 564,7	143,1 581,7	147,3 598,7
SVA-P-800	E [kNm/m] R [kN/m]	178,3 543,6	185,7 566,3	193,1 588,7	200,5 611,4	207,9 633,8	215,3 656,5	222,8 679,2	230,1 701,6	237,6 724,3	245,0 747,0	252,3 769,4	259,8 792,1
SVA-P-1000	E [kNm/m] R [kN/m]	274,2 668,7	285,6 696,6	297,0 724,4	308,4 752,3	319,9 780,2	331,3 808,0	342,7 835,9	354,1 863,8	365,6 891,6	377,0 919,5	388,4 947,4	399,8 975,2

- RPD (Rated Performance Data) values: impact velocity 150mm/s, temperature 23°C, impact angle 0°, for most common used rubber compound: blend of natural rubber (NR) and styrene-butadiene rubber (SBR)
- Valores RPD (Rated Performance Data): velocidad de impacto 150mm/s, temperatura 23°C, ángulo de impacto 0°, para el compuesto de caucho más usado: mezcla de caucho natural (NR) y caucho estireno-butadieno (SBR)

C3	C4	C5	B1	B2	B3	B4	B5	A1	A2	A3	A4	A5	Grade Grado	Size Tamaño
9,0 144,4	9,1 147,3	9,4 151,5	9,6 154,4	9,8 157,3	10,0 161,6	10,2 164,4	10,5 168,7	10,6 171,6	10,8 174,5	11,0 177,4	11,2 180,4	11,4 183,5	E [kNm/m] R [kN/m]	SVA-P-150
18,2 221,4	18,6 226,4	19,1 232,6	19,6 238,8	20,1 245,0	20,6 251,3	21,0 256,2	21,5 262,5	22,0 268,7	22,6 275,0	23,1 281,6	23,6 288,2	24,2 295,1	E [kNm/m] R [kN/m]	SVA-P-200
26,4 256,5	26,9 261,4	27,4 266,4	27,9 271,3	28,6 277,3	29,3 284,2	30,0 291,1	30,7 298,1	31,4 305,0	32,1 312,1	32,9 319,4	33,7 326,8	34,4 334,4	E [kNm/m] R [kN/m]	SVA-P-250
39,3 319,3	40,2 326,7	41,2 335,0	42,1 342,5	43,4 352,4	44,6 362,4	45,7 371,5	46,9 381,5	48,1 391,4	49,4 401,6	50,7 412,1	52,0 422,9	53,4 433,9	E [kNm/m] R [kN/m]	SVA-P-300
68,2 416,1	70,2 427,9	72,1 439,7	74,0 450,9	75,9 462,7	77,8 474,5	79,8 486,4	81,6 497,6	83,5 509,4	85,5 521,5	87,6 533,9	89,6 546,5	91,8 559,5	E [kNm/m] R [kN/m]	SVA-P-400
106,3 518,5	109,3 533,4	112,4 548,3	115,5 563,2	118,3 577,2	121,1 590,6	123,9 604,5	126,8 618,5	129,6 632,4	132,6 646,6	135,5 661,2	138,6 676,1	141,7 691,3	E [kNm/m] R [kN/m]	SVA-P-500
151,6 616,1	155,8 633,1	160,0 650,6	164,2 667,6	168,4 684,6	172,7 702,0	176,9 719,0	181,2 736,4	185,3 753,4	189,6 770,8	194,0 788,6	198,5 806,8	203,0 825,4	E [kNm/m] R [kN/m]	SVA-P-600
267,2 814,8	274,6 837,1	282,0 859,8	289,5 882,5	296,8 904,9	304,3 927,6	311,6 950,0	319,1 972,7	326,5 995,4	334,1 1019	341,9 1042	349,9 1067	358,1 1092	E [kNm/m] R [kN/m]	SVA-P-800
411,3 1003	422,7 1031	434,1 1059	445,5 1087	457,0 1115	468,4 1142	479,8 1170	491,2 1198	502,7 1226	514,3 1255	526,3 1284	538,5 1314	551,1 1344	E [kNm/m] R [kN/m]	SVA-P-1000

- RPD (Rated Performance Data) values: impact velocity 150mm/s, temperature 23°C, impact angle 0°, for most common used rubber compound: blend of natural rubber (NR) and styrene-butadiene rubber (SBR)
- Valores RPD (Rated Performance Data): velocidad de impacto 150mm/s, temperatura 23°C, ángulo de impacto 0°, para el compuesto de caucho más usado: mezcla de caucho natural (NR) y caucho estireno-butadieno (SBR)

CHARACTERISTIC PERFORMANCE CURVE / CURVA CARACTERÍSTICA DE RENDIMIENTO:

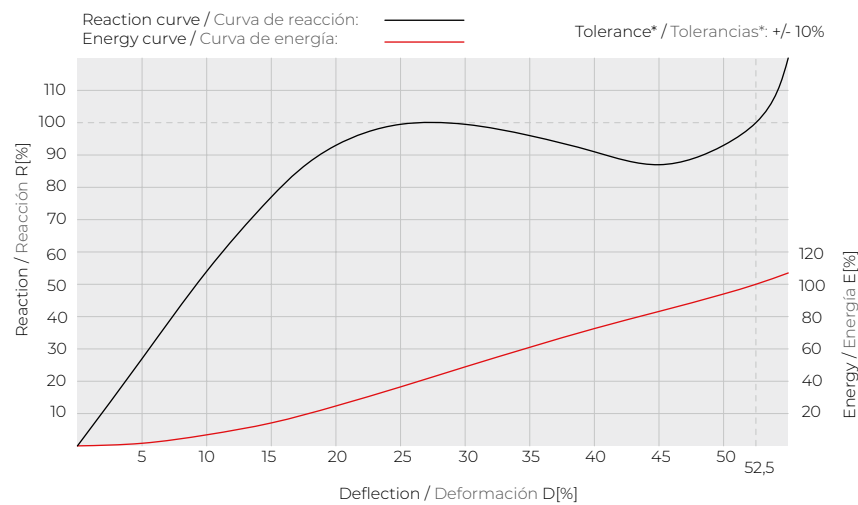

* Standard Reaction & Energy tolerances, tighter tolerances upon request
* Tolerancias de Reacción y Energía estándar, tolerancias más restrictivas bajo demanda

Reaction & Energy percentage values at intermediate Deflections Valores porcentuales de Reacción y Energía en Deformaciones intermedias													
Deflection / Deformación	D[%]	5	10	15	20	25	30	35	40	45	50	52,5	55
Reaction / Reacción	R[%]	27	54	77	93	99	100	96	91	87	93	100	120
Energy / Energía	E[%]	2	7	14	25	37	49	61	72	83	94	100	107

CORRECTION FACTORS / FACTORES DE CORRECCIÓN:

Velocity correction factors* / Factores de corrección de velocidad*

VF	Impact Velocity / Velocidad de impacto											
	1 [mm/s]	25 [mm/s]	50 [mm/s]	100 [mm/s]	150 [mm/s]	200 [mm/s]	250 [mm/s]	300 [mm/s]	350 [mm/s]	400 [mm/s]	450 [mm/s]	500 [mm/s]
SVA-P-150	0,815	0,913	0,946	0,980	1	1,015	1,026	1,036	1,044	1,051	1,058	1,063
SVA-P-200	0,827	0,913	0,946	0,980	1	1,015	1,026	1,036	1,044	1,051	1,058	1,063
SVA-P-250	0,837	0,913	0,946	0,980	1	1,015	1,026	1,036	1,044	1,051	1,058	1,063
SVA-P-300	0,844	0,913	0,946	0,980	1	1,015	1,026	1,036	1,044	1,051	1,058	1,063
SVA-P-400	0,857	0,913	0,946	0,980	1	1,015	1,026	1,036	1,044	1,051	1,058	1,063
SVA-P-500	0,867	0,913	0,946	0,980	1	1,015	1,026	1,036	1,044	1,051	1,058	1,063
SVA-P-600	0,875	0,913	0,946	0,980	1	1,015	1,026	1,036	1,044	1,051	1,058	1,063
SVA-P-800	0,888	0,913	0,946	0,980	1	1,015	1,026	1,036	1,044	1,051	1,058	1,063
SVA-P-1000	0,898	0,913	0,946	0,980	1	1,015	1,026	1,036	1,044	1,051	1,058	1,063

Temperature correction factors* / Factores de corrección de temperatura*

Temperature [°C] Temperatura [°C]	-30	-20	-10	0	+10	+23	+30	+40	+50
TF	1,35	1,25	1,16	1,09	1,04	1	0,97	0,94	0,91

Angle correction factors* / Factores de corrección de ángulo*

Angle [°] Ángulo [°]	0	3	5	8	10	15	20
AF (Energy / Energía)	1	0,98	0,97	0,95	0,92	0,84	0,77
AF (Reaction / Reacción)	1	1	1	1	1	1	1

* Values for correction factors correspond to the most used rubber compound: blend of natural rubber (NR) and styrene-butadiene rubber (SBR)

* Los valores de los factores de corrección corresponden al compuesto de caucho más usado: mezcla de caucho natural (NR) y caucho estireno-butadieno (SBR)

C TYPE FENDERS DEFENSAS TIPO C

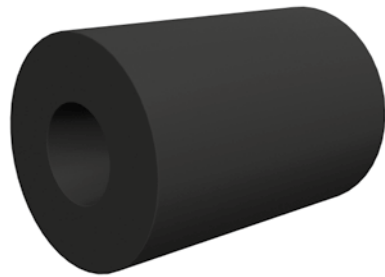

DIMENSIONS / DIMENSIONES:

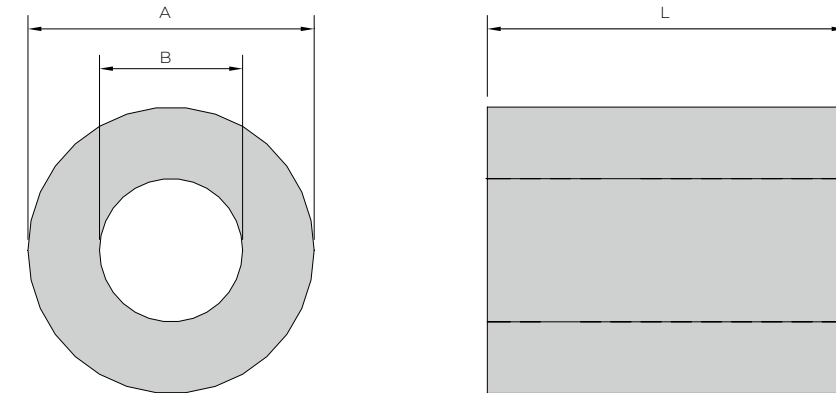

Features:

- First specifically designed type of rubber fender
- Strong and durable
- Proven in practice for more than 60 years
- Simple and economic
- Progressive reaction/deflection curve
- Easy installation
- Broad range of sizes and lengths

Características:

- Primer elemento de caucho diseñado específicamente como defensa marina
- Robustas y duraderas
- Más de 60 años de experiencia de uso
- Sencillas y económicas
- Curva reacción/deformación progresiva
- Instalación sencilla
- Amplio rango de dimensiones y longitudes

Applications:

- All kind of berths (coastal, river, tidal & non-tidal):
- General cargo terminals
- Bulk terminals
- Container terminals
- RoRo & ferry terminals
- Cruise terminals
- Fishing and barge berths
- Pontoons and floating structures

Aplicaciones:

- Todos los tipos de atraques (costeros, fluviales, sometidos o no sometidos a mareas)
- Terminales de carga general
- Terminales de carga en granel
- Terminales de contenedores
- RoRo y terminales de transbordadores
- Terminales de cruceros
- Muelles de pesqueros, de barcazas
- Pontonas y estructuras flotantes



Fender Defensa []	ØA [mm]	ØB [mm]	Weight Peso [kg/m]	Fender Defensa []	ØA [mm]	ØB [mm]	Weight Peso [kg/m]	Fender Defensa []	ØA [mm]	ØB [mm]	Weight Peso [kg/m]
C 150-75	150	75	16	C 700-350	700	350	340	C 1800-900	1800	900	2250
C 200-100	200	100	28	C 800-400	800	400	445	C 1900-950	1900	950	2510
C 250-125	250	125	43	C 900-450	900	450	565	C 2000-1000	2000	1000	2780
C 300-150	300	150	63	C 1000-500	1000	500	695	C 2100-1050	2100	1050	3065
C 380-190	380	190	100	C 1100-550	1100	550	840	C 2200-1100	2200	1100	3365
C 400-200	400	200	110	C 1200-600	1200	600	1000	C 2300-1150	2300	1150	3677
C 450-225	450	225	140	C 1300-650	1300	650	1175	C 2400-1200	2400	1200	4005
C 480-240	480	240	160	C 1400-700	1400	700	1365	C 2500-1250	2500	1250	4344
C 500-250	500	250	175	C 1500-750	1500	750	1565	C 2600-1300	2600	1300	4700
C 540-270	540	270	195	C 1600-800	1600	800	1780	C 2700-1350	2700	1350	5067
C 600-300	600	300	250	C 1700-850	1700	850	2010	C 2800-1400	2800	1400	5450

Standard lengths / Longitudes estándares: L=1000, L=1500, L=2000, L=2500, L=3000mm.
any length less than 3000mm is also available / cualquier longitud menor de 3000mm es también disponible.

PERFORMANCE DATA / CARACTERÍSTICAS:

Size Tamaño	Grade Grado	B1	B2	B3	B4	B5	A1	A2	A3	A4	A5
C 150-75	E [kNm/m]	1,60	1,66	1,73	1,79	1,86	2,55	2,65	2,75	2,86	2,96
	R [kN/m]	47,1	48,9	50,8	52,7	54,6	75,0	78,0	81,0	84,0	87,0
C 200-100	E [kNm/m]	2,80	2,91	3,02	3,14	3,25	4,50	4,68	4,86	5,04	5,22
	R [kN/m]	62,2	64,7	67,2	69,7	72,2	100,0	104,0	108,0	112,0	116,0
C 250-125	E [kNm/m]	4,40	4,58	4,75	4,93	5,10	7,00	7,28	7,56	7,84	8,12
	R [kN/m]	78,6	81,7	84,9	88,0	91,1	125,0	130,0	135,0	140,0	145,0
C 300-150	E [kNm/m]	6,20	6,45	6,70	6,94	7,19	9,90	10,30	10,69	11,09	11,48
	R [kN/m]	91,2	94,8	98,5	102,1	105,8	145,6	151,4	157,2	163,1	168,9
C 380-190	E [kNm/m]	9,9	10,3	10,7	11,1	11,5	15,8	16,4	17,1	17,7	18,3
	R [kN/m]	115,1	119,7	124,3	128,9	133,5	183,7	191,1	198,4	205,8	213,1
C 400-200	E [kNm/m]	10,9	11,3	11,8	12,2	12,6	17,5	18,2	18,9	19,6	20,3
	R [kN/m]	121,1	126,0	130,8	135,6	140,5	194,4	202,2	210,0	217,8	225,6
C 450-225	E [kNm/m]	13,9	14,5	15,0	15,6	16,1	22,2	23,1	24,0	24,9	25,8
	R [kN/m]	137,6	143,1	148,6	154,1	159,6	219,8	228,6	237,4	246,2	255,0

C TYPE FENDERS DEFENSAS TIPO C

PERFORMANCE DATA (CONTINUATION) / CARACTERÍSTICAS (CONTINUACIÓN):

Size Tamaño	Grade Grado	B1	B2	B3	B4	B5	A1	A2	A3	A4	A5
C 480-240	E [kNm/m] R [kN/m]	15,8 146,3	16,4 152,1	17,1 158,0	17,7 163,9	18,3 169,7	25,2 233,3	26,2 242,7	27,2 252,0	28,2 261,3	29,2 270,7
C 500-250	E [kNm/m] R [kN/m]	17,1 151,3	17,8 157,4	18,5 163,4	19,2 169,5	19,8 175,5	27,4 242,5	28,5 252,2	29,6 261,9	30,7 271,6	31,8 281,3
C 540-270	E [kNm/m] R [kN/m]	19,2 157,4	20,0 163,7	20,7 170,0	21,5 176,3	22,3 182,6	30,7 251,6	31,9 261,7	33,2 271,8	34,4 281,8	35,6 291,9
C 600-300	E [kNm/m] R [kN/m]	24,6 182,2	25,6 189,5	26,6 196,8	27,6 204,1	28,5 211,4	39,4 291,9	41,0 303,5	42,6 315,2	44,1 326,9	45,7 338,5
C 700-350	E [kNm/m] R [kN/m]	33,5 212,0	34,8 220,5	36,2 229,0	37,5 237,5	38,9 245,9	53,6 339,2	55,7 352,8	57,9 366,4	60,0 379,9	62,2 393,5
C 800-400	E [kNm/m] R [kN/m]	43,8 243,3	45,6 253,1	47,3 262,8	49,1 272,5	50,8 282,3	70,0 388,9	72,8 404,4	75,6 420,0	78,4 435,6	81,2 451,1
C 900-450	E [kNm/m] R [kN/m]	55,4 272,9	57,6 283,8	59,8 294,7	62,1 305,7	64,3 316,6	88,6 436,4	92,1 453,9	95,7 471,4	99,2 488,8	102,8 506,3
C 1000-500	E [kNm/m] R [kN/m]	68,1 302,7	70,8 314,8	73,6 326,9	76,3 339,0	79,0 351,1	109,0 484,4	113,4 503,8	117,7 523,2	122,1 542,6	126,4 562,0
C 1100-550	E [kNm/m] R [kN/m]	82,7 333,5	86,0 346,8	89,3 360,1	92,6 373,5	95,9 386,8	132,0 532,3	137,3 553,5	142,6 574,8	147,8 596,1	153,1 617,4
C 1200-600	E [kNm/m] R [kN/m]	98,5 364,9	102,4 379,4	106,4 394,0	110,3 408,6	114,3 423,2	158,0 585,2	164,3 608,6	170,6 632,0	177,0 655,4	183,3 678,8
C 1300-650	E [kNm/m] R [kN/m]	116,0 395,9	120,6 411,7	125,3 427,6	129,9 443,4	134,6 459,2	185,0 631,4	192,4 656,7	199,8 681,9	207,2 707,2	214,6 732,4
C 1400-700	E [kNm/m] R [kN/m]	134,0 425,4	139,4 442,4	144,7 459,4	150,1 476,4	155,4 493,5	215,0 682,5	223,2 709,8	232,2 737,1	240,8 764,4	249,4 791,7
C 1500-750	E [kNm/m] R [kN/m]	154,0 455,6	160,2 473,8	166,3 492,1	172,5 510,3	178,6 528,5	246,0 727,8	255,8 756,9	265,7 786,0	275,5 815,1	285,4 844,3
C 1600-800	E [kNm/m] R [kN/m]	175,0 486,1	182,0 505,6	189,0 525,0	196,0 544,4	203,0 563,9	280,0 777,8	291,2 808,9	302,4 840,0	313,6 871,1	324,8 902,2
C 1700-850	E [kNm/m] R [kN/m]	198,0 517,0	205,9 537,7	213,8 558,3	221,8 579,0	229,7 599,7	316,0 825,1	328,6 858,1	341,3 891,1	353,9 924,1	366,6 957,1
C 1800-900	E [kNm/m] R [kN/m]	222,0 548,1	230,9 570,1	239,8 592,0	248,6 613,9	257,5 635,9	355,0 876,5	369,2 911,6	383,4 946,7	397,6 981,7	411,8 1017
C 1900-950	E [kNm/m] R [kN/m]	247,0 577,1	256,9 600,2	266,8 623,3	276,6 646,4	286,5 669,4	395,0 922,9	410,8 959,8	426,6 996,7	442,4 1034	458,2 1071
C 2000-1000	E [kNm/m] R [kN/m]	274,0 608,9	285,0 633,2	296,0 657,6	306,9 682,0	317,8 706,3	438,0 973,3	455,5 1012	473,0 1051	490,6 1090	508,1 1129
C 2100-1050	E [kNm/m] R [kN/m]	302,0 638,5	314,1 664,0	326,2 689,6	338,2 715,1	350,3 740,6	483,0 1021	502,3 1062	521,6 1103	541,0 1144	560,3 1185
C 2200-1100	E [kNm/m] R [kN/m]	331,0 668,7	344,2 695,4	357,5 722,2	370,7 748,9	384,0 775,7	530,0 1071	551,2 1114	572,4 1156	593,6 1199	614,8 1242
C 2300-1150	E [kNm/m] R [kN/m]	362,0 698,8	376,5 726,8	391,0 754,7	405,4 782,7	419,9 810,7	579,0 1118	602,2 1163	625,3 1207	648,5 1252	671,6 1297
C 2400-1200	E [kNm/m] R [kN/m]	394,0 729,6	409,8 758,8	425,5 788,0	441,3 817,2	457,0 846,4	630,0 1167	655,2 1213	680,4 1260	705,6 1307	730,8 1353
C 2500-1250	E [kNm/m] R [kN/m]	428,0 760,2	445,1 790,6	462,2 821,0	479,4 851,4	496,5 881,8	684,0 1215	711,4 1264	738,7 1312	766,1 1361	793,4 1409
C 2600-1300	E [kNm/m] R [kN/m]	462,0 789,7	480,5 821,3	499,0 852,9	517,4 884,5	535,9 916,1	740,0 1265	769,6 1316	799,2 1366	828,8 1417	858,4 1467
C 2700-1350	E [kNm/m] R [kN/m]	499,0 820,7	519,0 853,6	539,0 886,4	559,0 919,2	579,0 952,0	798,0 1313	829,9 1365	861,8 1418	893,7 1470	925,7 1523
C 2800-1400	E [kNm/m] R [kN/m]	536,0 850,8	557,4 884,8	578,9 918,9	600,3 952,9	621,8 986,9	858,0 1362	892,3 1416	926,6 1471	961,0 1525	995,3 1580

Characteristic performance curve / Curva característica de rendimiento:

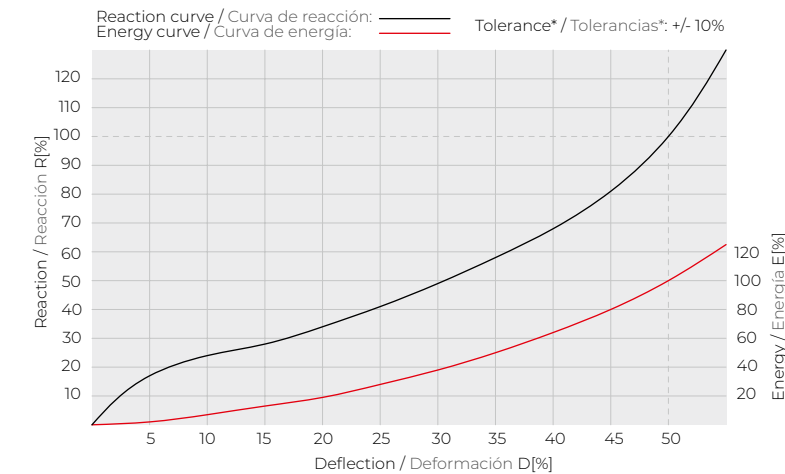

* Standard Reaction & Energy tolerances, tighter tolerances upon request
* Tolerancias de Reacción y Energía estándar, tolerancias más restrictivas bajo demanda

Reaction & Energy percentage values at intermediate Deflections Valores porcentuales de Reacción y Energía en Deformaciones intermedias

Deflection / Deformación	D [%]	5	10	15	20	25	30	35	40	45	50	55
Reaction / Reacción	R [%]	17	24	28	34	41	49	58	68	81	100	130
Energy / Energía	E [%]	2	7	13	19	28	38	50	64	80	100	125

FIXING METHODS / MÉTODOS DE SUJECIÓN:

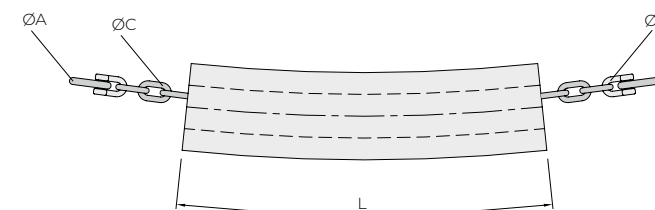

Size Tamaño	Length Longitud	Anchor Anclaje	Chain Cadena	Shackle Grillete
[]	L [mm]	ØA [mm]	ØC [kg/m]	ØS [kg/m]
C 150-75	≤3000	30	18	16
C 200-100	≤3000	30	22	20
C 250-125	≤3000	30	24	22
C 300-150	≤3000	30	26	25
C 380-190	≤3000	40	28	28
C 400-200	≤3000	40	30	28
C 450-225	≤3000	40	30	28
C 480-240	≤3000	40	32	32
C 500-250	≤3000	40	32	32
C 540-270	≤3000	40	34	35

C TYPE FENDERS DEFENSAS TIPO C

FIXING METHODS (CONTINUATION) / MÉTODOS DE SUJECIÓN (CONTINUACIÓN):

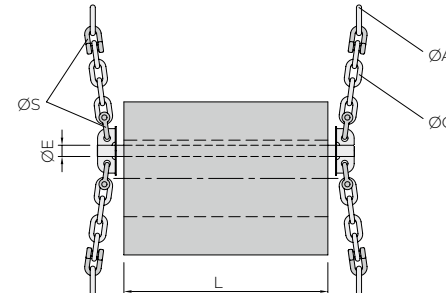
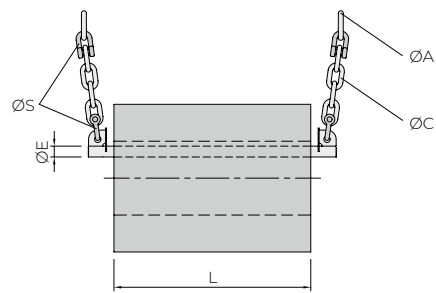

Size Tamaño	Length Longitud	Shaft Eje	Anchor Anclaje	Chain Cadena	Shackle Grillete
[]	L [mm]	ØE [kg/m]	ØA [mm]	ØC [kg/m]	ØS [kg/m]
C 600-300	1000	50	30	22	20
	1500	60	30	26	25
	2000	70	40	30	28
	2500	80	40	32	32
	3000	90	40	36	35
C 700-350	1000	50	30	24	22
	1500	70	40	28	28
	2000	80	40	32	32
	2500	90	40	36	35
	3000	100	50	38	38
C 800-400	1000	50	30	24	22
	1500	70	40	30	28
	2000	80	40	34	32
	2500	100	50	38	38
	3000	100	50	42	38
C 900-450	1000	60	30	26	25
	1500	80	40	32	32
	2000	90	40	36	35
	2500	100	50	40	38
	3000	110	50	44	45
C 1000-500	1000	70	40	28	28
	1500	80	40	32	32
	2000	100	50	38	38
	2500	100	50	42	38
	3000	110	50	46	45
C 1100-550	1000	70	40	28	28
	1500	80	40	34	32
	2000	100	50	40	38
	2500	110	50	44	45
	3000	110	60	48	45
C 1200-600	1000	70	40	30	28
	1500	90	40	36	35
	2000	100	50	42	38
	2500	110	50	46	45
	3000	110	60	50	45

* Stud link chain / Cadena con concreto

Size Tamaño	Length Longitud	Shaft Eje	Anchor Anclaje	Chain Cadena	Shackle Grillete
[]	L [mm]	ØE [kg/m]	ØA [mm]	ØC [kg/m]	ØS [kg/m]
C 1300-650	1000	70	40	30	28
	1500	100	50	38	38
	2000	110	50	44	45
	2500	110	60	48	45
	3000	120	60	42*	50
C 1400-700	1000	80	40	32	32
	1500	100	50	38	38
	2000	110	50	44	45
	2500	110	60	50	45
	3000	120	70	46*	50
C 1500-750	1000	90	40	34	35
	1500	100	50	40	38
	2000	110	50	46	45
	2500	110	60	42*	45
	3000	150	60	48*	50
C 1600-800	1000	90	40	34	35
	1500	100	50	42	38
	2000	110	60	48	45
	2500	120	60	44*	50
	3000	150	70	48*	50
C 1700-850	1000	90	40	36	35
	1500	110	50	44	45
	2000	120	60	50	50
	2500	120	60	44*	50
	3000	150	80	50*	50
C 1800-900	1000	90	40	36	35
	1500	110	50	44	45
	2000	110	60	50	45
	2500	120	70	46*	50
	3000	150	80	50*	50
C 1900-950	1000	100	50	38	38
	1500	110	50	46	45
	2000	120	60	52	50
	2500	150	70	48*	50
	3000	180	80	54*	65

* Stud link chain / Cadena con concreto

FIXING METHODS (CONTINUATION) / MÉTODOS DE SUJECIÓN (CONTINUACIÓN):

Size Tamaño	Length Longitud	Shaft Eje	Anchor Anclaje	Chain Cadena	Shackle Grillete
[]	L [mm]	ØE [kg/m]	ØA [mm]	ØC [kg/m]	ØS [kg/m]
C 2000-1000	1000	100	50	38	38
	1500	110	50	46	45
	2000	120	60	44*	50
	2500	150	80	50*	50
	3000	180	80	54*	65
C 2100-1050	1000	100	50	40	38
	1500	110	60	48	45
	2000	120	60	44*	50
	2500	150	80	50*	50
	3000	180	80	56*	65
C 2200-1100	1000	100	50	40	38
	1500	110	60	50	45
	2000	120	60	44*	50
	2500	150	80	52*	65
	3000	180	80	56*	65
C 2300-1150	1000	100	50	42	38
	1500	110	60	50	45
	2000	150	70	48*	50
	2500	180	80	56*	65
	3000	180	80	56*	65
C 2400-1200	1000	100	50	42	38
	1500	120	70	46*	50
	2000	150	70	48*	50
	2500	180	80	56*	65
	3000	180	80	60*	65

* Stud link chain / Cadena con concreto

Size Tamaño	Length Longitud	Shaft Eje	Anchor Anclaje	Chain Cadena	Shackle Grillete
[]	L [mm]	ØE [kg/m]	ØA [mm]	ØC [kg/m]	ØS [kg/m]
C 2500-1250	1000	110	50	44	45
	1500	120	70	46*	50
	2000	150	80	50*	50
	2500	180	80	56*	65
	3000	180	90	62*	65
C 2600-1300	1000	110	50	44	45
	1500	120	60	44*	50
	2000	150	80	50*	50
	2500	180	80	56*	65
	3000	180	90	62*	65
C 2700-1350	1000	110	50	44	45
	1500	120	60	44*	50
	2000	150	80	52*	50
	2500	180	80	58*	65
	3000	180	90	64*	65
C 2800-1400	1000	110	50	46	45
	1500	150	70	46*	50
	2000	180	80	54*	65
	2500	180	80	60*	65
	3000	180	90	66*	65

* Stud link chain / Cadena con concreto

DIMENSIONAL TOLERANCES / TOLERANCIAS DIMENSIONALES:

Dimension / Dimensión	Tolerances / Tolerancias
Outer diameter / Diámetro exterior	±4%
Inner diameter / Diámetro interior	±4%
Length / Longitud	±30mm

FL-N TYPE FENDERS

DEFENSAS TIPO FL-N



Features:

- Comply with standard ISO 17375: "Floating pneumatic rubber fenders"
- Extensive testing program
- Berthing angles up to 15°
- Excellent compressibility and elasticity
- Low hull pressures
- Easy installation
- Wide range of sizes
- Optional chain & tyre net for heavy duty applications
- Fender can be deflated for easy relocation

Applications:

- Ship to ship berthing
- Navy vessels
- In ports with extreme tidal variations
- All kind of berths
- All types of vessels

Características:

- Cumplen con la norma ISO 17375: "Defensas neumáticas flotantes"
- Programa extenso de ensayos
- Ángulos de atraque de hasta 15°
- Compresibilidad y elasticidad excelentes
- Bajas presiones sobre el casco de buque
- Instalación sencilla
- Gran rango de dimensiones
- Opcionalmente se pueden proteger con una malla de cubiertas de neumáticos para aplicaciones exigentes
- Se pueden desinflar para su sencilla recolocación

Aplicaciones:

- Atraques buque a buque
- Buques militares
- En puertos con grandes variaciones de niveles de carrera de mareas
- Todo tipo de muelles
- Todo tipo de buques



DIMENSIONS AND WEIGHTS / DIMENSIONES Y PESOS:

Sling type /
Sin malla:

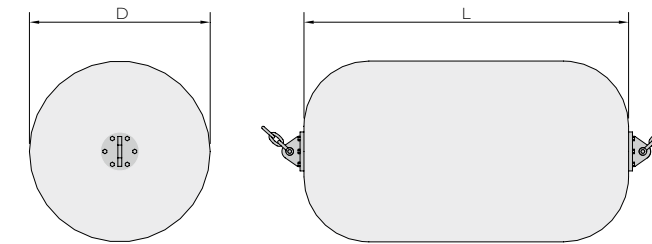

With Chan&Tyre Net /
Con malla:

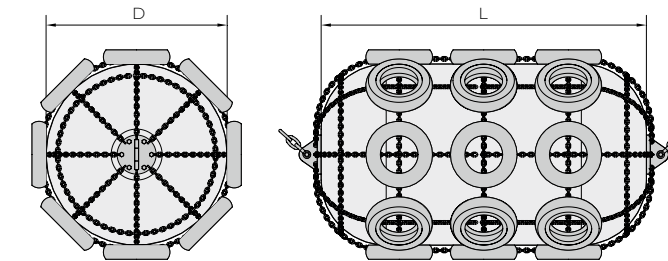

Fender Defensa	ØD	L	Weight / Peso	
			Body Cuerpo	Chan net Malla
[]	[mm]	[mm]	[kg]	[kg]
FL-N 300x600	300	600	12	-
FL-N 500-800	500	800	25	-
FL-N 500-1000	500	1000	35	-
FL-N 600-1000	600	1000	45	-
FL-N 600-1200	600	1200	55	-
FL-N 700-1500	700	1500	85	-
FL-N 800-1200	800	1200	75	100
FL-N 800-1500	800	1500	95	110
FL-N 1000-1500	1000	1500	140	170
FL-N 1000-2000	1000	2000	170	200
FL-N 1200-1800	1200	1800	180	210
FL-N 1200-2000	1200	2000	200	220
FL-N 1200-3000	1200	3000	300	310
FL-N 1350-2500	1350	2500	240	330
FL-N 1500-2500	1500	2500	300	400
FL-N 1500-3000	1500	3000	350	440
FL-N 1500-4000	1500	4000	450	580
FL-N 1700-3000	1700	3000	430	660
FL-N 2000-3000	2000	3000	550	880
FL-N 2000-3500	2000	3500	650	920

Fender Defensa	ØD	L	Weight / Peso	
			Body Cuerpo	Chan net Malla
[]	[mm]	[mm]	[kg]	[kg]
FL-N 2000-4000	2000	4000	740	1050
FL-N 2000-6000	2000	6000	950	1120
FL-N 2500-4000	2500	4000	1100	1510
FL-N 2500-5500	2500	5500	1350	1620
FL-N 2500-7200	2500	7200	1650	2020
FL-N 2500-7700	2500	7700	1750	2150
FL-N 2500-9100	2500	9100	2050	2500
FL-N 3000-5000	3000	5000	1700	2620
FL-N 3300-4500	3300	4500	1800	2360
FL-N 3300-5000	3300	5000	1950	2550
FL-N 3300-6000	3300	6000	2300	3000
FL-N 3300-6500	3300	6500	2250	3120
FL-N 3300-8600	3300	8600	2900	4050
FL-N 3300-10600	3300	10600	2850	4100
FL-N 4500-6400	4500	6400	3000	4680
FL-N 4500-7000	4500	7000	3250	5100
FL-N 4500-9000	4500	9000	4950	6200
FL-N 4500-11000	4500	11000	6000	7500
FL-N 4500-12000	4500	12000	6500	8150

FL-N TYPE FENDERS

DEFENSAS TIPO FL-N

PERFORMANCE DATA / CARACTERÍSTICAS:

Internal air pressure [50kPa] / Presión interna de aire [50kPa]

Size Tamaño	E	R	P*	Size Tamaño	E	R	P*	Size Tamaño	E	R	P*
[]	[kNm]	[kN]	[kPa]	[]	[kNm]	[kN]	[kPa]	[]	[kNm]	[kN]	[kPa]
FL-N 300-600	1,4	24	134	FL-N 1350-2500	111	439	130	FL-N 2500-9100	1631	3482	153
FL-N 500-800	4,9	52	130	FL-N 1500-2500	135	479	128	FL-N 3000-5000	1136	2021	135
FL-N 500-1000	6,3	67	134	FL-N 1500-3000	168	596	133	FL-N 3300-4500	1188	1921	130
FL-N 600-1000	8,8	78	130	FL-N 1500-4000	229	815	136	FL-N 3300-5000	1480	2394	134
FL-N 600-1200	10,7	95	132	FL-N 1700-3000	210	658	129	FL-N 3300-6000	1650	2669	142
FL-N 700-1500	18,7	142	136	FL-N 2000-3000	282	752	126	FL-N 3300-6500	1915	3097	145
FL-N 800-1200	17,4	116	123	FL-N 2000-3500	336	896	128	FL-N 3300-8600	2563	4148	155
FL-N 800-1500	23,7	158	132	FL-N 2000-4000	381	1018	132	FL-N 3300-10600	3338	5398	155
FL-N 1000-1500	35,5	189	126	FL-N 2000-6000	611	1631	136	FL-N 4500-6400	3238	3798	134
FL-N 1000-2000	50,1	267	134	FL-N 2500-4000	660	1409	141	FL-N 4500-7000	3792	4497	143
FL-N 1200-1800	59,4	264	123	FL-N 2500-5500	961	2051	149	FL-N 4500-9000	4960	5883	146
FL-N 1200-2000	69,4	308	129	FL-N 2500-7200	1308	2793	152	FL-N 4500-11000	6286	7453	151
FL-N 1200-3000	109	482	134	FL-N 2500-7700	1385	2960	158	FL-N 4500-12000	6987	8284	154

* P - Hull pressure

* P - Presión sobre el casco de buque

Internal air pressure [80kPa] / Presión interna de aire [80kPa]

Size Tamaño	E	R	P*	Size Tamaño	E	R	P*	Size Tamaño	E	R	P*
[]	[kNm]	[kN]	[kPa]	[]	[kNm]	[kN]	[kPa]	[]	[kNm]	[kN]	[kPa]
FL-N 300-600	1,7	31	173	FL-N 1350-2500	149	572	170	FL-N 2500-9100	2293	4505	199
FL-N 500-800	6,3	67	168	FL-N 1500-2500	174	620	166	FL-N 3000-5000	1593	2608	174
FL-N 500-1000	8,2	87	174	FL-N 1500-3000	218	776	173	FL-N 3300-4500	1673	2491	168
FL-N 600-1000	11,2	100	167	FL-N 1500-4000	296	1053	176	FL-N 3300-5000	2043	3040	180
FL-N 600-1200	13,8	123	171	FL-N 1700-3000	272	853	168	FL-N 3300-6000	2339	3479	185
FL-N 700-1500	24,1	184	176	FL-N 2000-3000	386	1030	172	FL-N 3300-6500	2707	4029	188
FL-N 800-1200	23,1	154	160	FL-N 2000-3500	440	1174	168	FL-N 3300-8600	3657	5442	202
FL-N 800-1500	30,6	204	170	FL-N 2000-4000	506	1351	174	FL-N 3300-10600	4677	6959	199
FL-N 1000-1500	45,7	244	163	FL-N 2000-6000	790	2109	176	FL-N 4500-6400	4572	4986	175
FL-N 1000-2000	64,7	345	173	FL-N 2500-4000	931	1831	184	FL-N 4500-7000	5337	5823	185
FL-N 1200-1800	77,3	344	160	FL-N 2500-5500	1353	2659	194	FL-N 4500-9000	6948	7581	188
FL-N 1200-2000	89,5	398	166	FL-N 2500-7200	1864	3660	203	FL-N 4500-11000	8828	9632	188
FL-N 1200-3000	140	623	173	FL-N 2500-7700	1979	3888	206	FL-N 4500-12000	9667	10548	196

* P - Hull pressure

* P - Presión sobre el casco de buque

CHARACTERISTIC PERFORMANCE CURVE / CURVA CARACTERÍSTICA DE RENDIMIENTO:

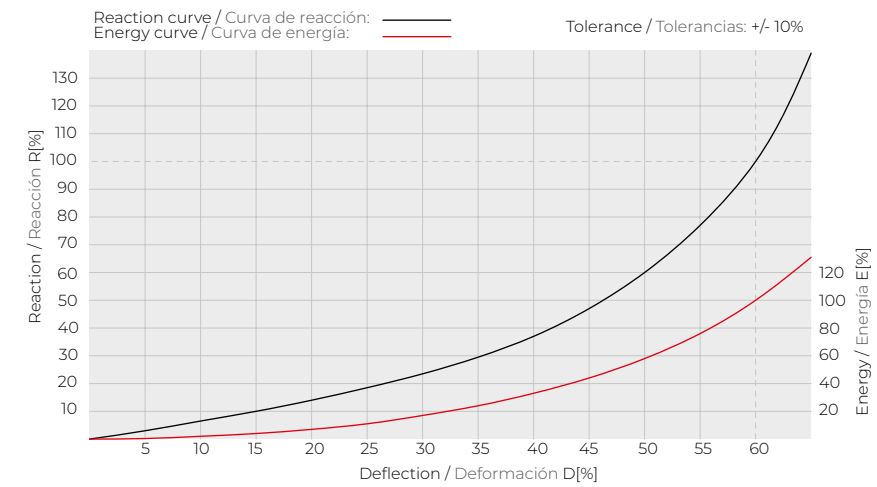

Reaction & Energy percentage values at intermediate Deflections
Valores porcentuales de Reacción y Energía en Deformaciones intermedias

Deflection / Deformación	D[%]	5	10	15	20	25	30	35	40	45	50	55	60	65
Reaction / Reacción	R[%]	3	7	10	14	19	24	30	37	47	60	77	100	139
Energy / Energía	E[%]	0,5	2	4	7	11	17	24	33	44	58	76	100	131

STANDARD COLOURS / COLORES ESTÁNDAR:



FL-E TYPE FENDERS

DEFENSAS TIPO FL-E



DIMENSIONS / DIMENSIONES:

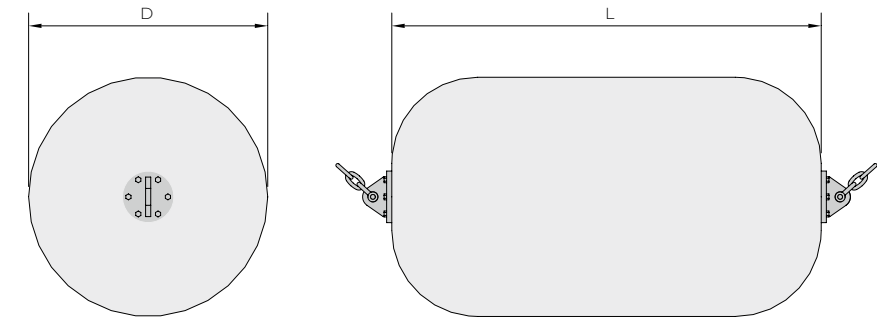

Features:

- High energy, low reaction
- Strong and durable
- Unsinkable
- Low hull pressures
- PE foam absorbs the impacts, skin resists wear & tear
- Various foam densities available
- Easy installation
- Wide range of sizes
- No necessity for chain & tyre net
- Non-marking skin

Applications:

- Ship to ship berthing
- Navy vessels
- Cruise vessels
- Bulk cargo vessels
- Container vessels
- RoRo & ferries
- General cargo vessels
- Oil & gas tankers

Características:

- Gran absorción de energía, baja reacción
- Robustas y duraderas
- Insumergibles
- Bajas presiones sobre el casco de buque
- La espuma de PE absorbe impactos, el recubrimiento exterior resiste el desgaste
- Disponibles diferentes densidades de espuma
- Instalación sencilla
- Gran rango de dimensiones
- Sin necesidad de la malla protectora de neumáticos
- El recubrimiento no deja marca en los cascos de buques

Aplicaciones:

- Atraques buque a buque
- Buques militares
- Cruceros
- Graneleros
- Portacontenedores
- RoRo y transbordadores
- Buques de carga general
- Petroleros y gaseros

Fender Defensa	ØD	L
[]	[mm]	[mm]
FL-E 600x1200	600	1200
FL-E 600x1800	600	1800
FL-E 600x2400	600	2400
FL-E 600x3000	600	3000
FL-E 700x1500	700	1500
FL-E 900x1500	900	1500
FL-E 900x1800	900	1800
FL-E 900x2400	900	2400
FL-E 900x3000	900	3000
FL-E 900x3700	900	3700
FL-E 900x4300	900	4300
FL-E 1000x1500	1000	1500
FL-E 1000x2000	1000	2000
FL-E 1200x1800	1200	1800
FL-E 1200x2000	1200	2000
FL-E 1200x2400	1200	2400
FL-E 1200x3000	1200	3000
FL-E 1200x3700	1200	3700
FL-E 1200x4900	1200	4900
FL-E 1200x6100	1200	6100
FL-E 1350x2500	1350	2500
FL-E 1500x2400	1500	2400
FL-E 1500x3000	1500	3000
FL-E 1500x3700	1500	3700

Fender Defensa	ØD	L
[]	[mm]	[mm]
FL-E 1500x4300	1500	4300
FL-E 1500x4900	1500	4900
FL-E 1500x5500	1500	5500
FL-E 1800x3700	1800	3700
FL-E 1800x4300	1800	4300
FL-E 1800x4900	1800	4900
FL-E 1800x5500	1800	5500
FL-E 1800x6100	1800	6100
FL-E 2000x3500	2000	3500
FL-E 2000x4000	2000	4000
FL-E 2000x4500	2000	4500
FL-E 2100x4300	2100	4300
FL-E 2100x4900	2100	4900
FL-E 2100x5500	2100	5500
FL-E 2100x6100	2100	6100
FL-E 2100x6700	2100	6700
FL-E 2400x3700	2400	3700
FL-E 2400x4300	2400	4300
FL-E 2400x4900	2400	4900
FL-E 2400x5500	2400	5500
FL-E 2400x6100	2400	6100
FL-E 2400x6700	2400	6700
FL-E 2500x4000	2500	4000
FL-E 2500x5500	2500	5500

Fender Defensa	ØD	L
[]	[mm]	[mm]
FL-E 2700x4300	2700	4300
FL-E 2700x4900	2700	4900
FL-E 2700x5500	2700	5500
FL-E 2700x6100	2700	6100
FL-E 2700x6700	2700	6700
FL-E 3000x4900	3000	4900
FL-E 3000x5500	3000	5500
FL-E 3000x6000	3000	6000
FL-E 3000x6100	3000	6100
FL-E 3000x6700	3000	6700
FL-E 3000x7300	3000	7300
FL-E 3300x4500	3300	4500
FL-E 3300x6500	3300	6500
FL-E 3400x5500	3400	5500
FL-E 3400x6100	3400	6100
FL-E 3400x6700	3400	6700
FL-E 3400x7300	3400	7300
FL-E 3700x6100	3700	6100
FL-E 3700x7300	3700	7300
FL-E 4000x7900	4000	7900
FL-E 4200x8000	4200	8000
FL-E 4300x8500	4300	8500
FL-E 4500x9000	4500	9000
FL-E 4500x10500	4500	10500

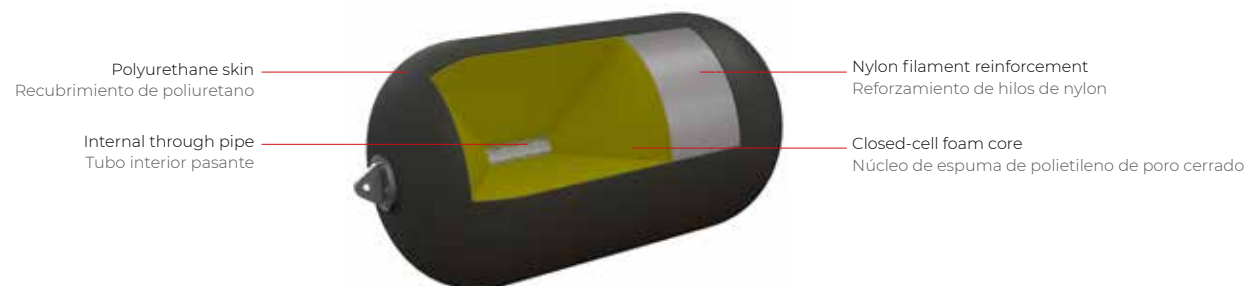

FL-E TYPE FENDERS

DEFENSAS TIPO FL-E

PERFORMANCE DATA / CARACTERÍSTICAS:

Capacity Capacidad	Standard Estándar		High Alta		Extra-High Extra alta		Super High Super alta	
P*	172kPa		224kPa		327kPa		447kPa	
Size Tamaño []	E	R	E	R	E	R	E	R
	[kNm]	[kN]	[kNm]	[kN]	[kNm]	[kN]	[kNm]	[kN]
FL-E 600x1200	14,7	88,3	19,6	117,7	27,8	166,7	39,2	235,4
FL-E 600x1800	24,6	147,1	32,8	196,1	47,5	284,4	63,9	382,5
FL-E 600x2400	34,4	205,9	45,9	274,6	65,5	392,3	88,3	539,4
FL-E 600x3000	44,2	264,8	57,3	343,2	85,2	509,9	116,3	696,3
FL-E 700x1500	27,5	137,3	35,3	176,5	51,0	255,0	68,6	343,2
FL-E 900x1500	39,2	196,1	58,8	264,8	78,5	382,5	107,9	519,8
FL-E 900x1800	49,0	215,7	68,6	274,6	98,1	402,1	137,3	559,0
FL-E 900x2400	78,5	304,0	98,1	392,3	147,1	578,6	196,1	784,5
FL-E 900x3000	98,1	392,3	127,5	509,9	186,3	745,3	255,0	1020
FL-E 900x3700	117,7	480,5	156,9	627,6	225,6	912,0	304,0	1245
FL-E 900x4300	137,3	568,8	186,3	735,5	264,8	1079	362,8	1481
FL-E 1000x1500	49,0	176,5	58,8	225,6	88,3	333,4	127,5	451,1
FL-E 1000x2000	68,6	255,0	88,3	333,4	127,5	480,5	176,5	657,0
FL-E 1200x1800	78,5	255,0	107,9	323,6	156,9	470,7	215,7	647,2
FL-E 1200x2000	88,3	284,4	117,7	362,8	176,5	529,6	235,4	725,7
FL-E 1200x2400	117,7	372,7	156,9	480,5	225,6	706,1	313,8	961,1
FL-E 1200x3000	156,9	490,3	205,9	637,4	304,0	941,4	411,9	1285
FL-E 1200x3700	196,1	608,0	255,0	784,5	372,7	1147	519,8	1579
FL-E 1200x4900	274,6	843,4	362,8	1098	519,8	1598	715,9	2187
FL-E 1200x6100	353,0	1079	460,9	1402	666,9	2050	912,0	2795
FL-E 1350x2500	147,1	421,7	196,1	549,2	284,4	794	392,3	1089
FL-E 1500x2400	176,5	441,3	235,4	578,6	353,0	843	480,5	1157
FL-E 1500x3000	245,2	598,2	313,8	774,7	460,9	1138	637,4	1549
FL-E 1500x3700	304,0	735,5	402,1	961,1	578,6	1412	794,3	1932
FL-E 1500x4300	362,8	892,4	470,7	1157	696,3	1687	951,2	2314
FL-E 1500x4900	421,7	1040	549,2	1343,5	804,1	1971	1108	2697
FL-E 1500x5500	480,5	1187	627,6	1540	921,8	2246	1255	3079
FL-E 1800x3700	402,1	823,8	529,6	1079	774,7	1569	1059	2157
FL-E 1800x4300	490,3	1000	637,4	1304	941,4	1902	1285	2599
FL-E 1800x4900	578,6	1177	755,1	1530	1098	2246	1510	3069
FL-E 1800x5500	666,9	1353	863,0	1765	1265	2579	1736	3530
FL-E 1800x6100	755,1	1530	980,7	1991	1432	2913	1952	3981
FL-E 2000x3500	451,1	843,4	588,4	1098	863,0	1608	1187	2197
FL-E 2000x4000	539,4	1000	706,1	1304	1030	1912	1402	2618
FL-E 2000x4500	627,6	1157	814,0	1510	1187	2206	1628	3020
FL-E 2100x4300	657,0	1147	863,0	1500	1255	2187	1716	2991
FL-E 2100x4900	774,7	1353	1010	1765	1481	2579	2020	3530
FL-E 2100x5500	892,4	1559	1167	2030	1697	2971	2324	4060
FL-E 2100x6100	1010	1765	1314	2295	1922	3354	2638	4590
FL-E 2100x6700	1128	1971	1471	2560	2148	3746	2942	5129
FL-E 2400x3700	715,9	1089	932	1422	1363	2079	1873	2854
FL-E 2400x4300	833,6	1275	1089	1667	1598	2432	2187	3334
FL-E 2400x4900	990,5	1520	1294	1971	1893	2883	2589	3942
FL-E 2400x5500	1147	1755	1491	2275	2187	3334	2991	4550
FL-E 2400x6100	1304	1991	1697	2589	2481	3776	3393	5168
FL-E 2400x6700	1461	2226	1893	2893	2775	4227	3795	5786
FL-E 2500x4000	804,1	1196	1040	1559	1520	2275	2089	3109
FL-E 2500x5500	1196	1775	1559	2324	2285	3403	3119	4648
FL-E 2700x4300	1059	1432	1373	1863	2010	2716	2746	3727
FL-E 2700x4900	1206	1638	1569	2128	2295	3109	3138	4256
FL-E 2700x5500	1402	1903	1824	2471	2658	3609	3638	4933
FL-E 2700x6100	1599	2158	2069	2815	3030	4109	4148	5619
FL-E 2700x6700	1785	2422	2324	3158	3393	4609	4648	6306
FL-E 3000x4900	1471	1785	1902	2324	2785	3403	3815	4648
FL-E 3000x5500	1706	2079	2216	2707	3246	3952	4433	5413
FL-E 3000x6000	1854	2295	2412	2981	3521	4364	4815	5972
FL-E 3000x6100	1942	2373	2530	3089	3697	4511	5060	6178
FL-E 3000x6700	2187	2667	2844	3472	4158	5070	5688	6943
FL-E 3000x7300	2452	3001	3099	3785	4531	5531	6198	7571
FL-E 3300x4500	1500	1687	1952	2197	2854	3217	3903	4393
FL-E 3300x6500	2422	2726	3148	3550	4599	5188	6306	7110
FL-E 3400x5500	2148	2599	2618	2893	3815	4236	5227	5796
FL-E 3400x6100	2363	2736	2903	3315	4374	4844	5982	6629
FL-E 3400x6700	2589	2873	3364	3736	4923	5462	6737	7473
FL-E 3400x7300	2824	3128	3677	4070	5374	5953	7345	8149
FL-E 3700x6100	2932	3148	3815	4089				
FL-E 3700x7300	3521	3785	4580	4923				
FL-E 4000x7900	4393	4384	5707	5698				
FL-E 4200x8000	4854	4688	6315	6090				
FL-E 4300x8500	5423	5031	7051	6541				
FL-E 4500x9000	6266	5688	8149	7394				
FL-E 4500x10500	7483	6757	9728	8787				

* P - Hull pressure
* P - Presión sobre el casco de buque

CHARACTERISTIC PERFORMANCE CURVE / CURVA CARACTERÍSTICA DE RENDIMIENTO:

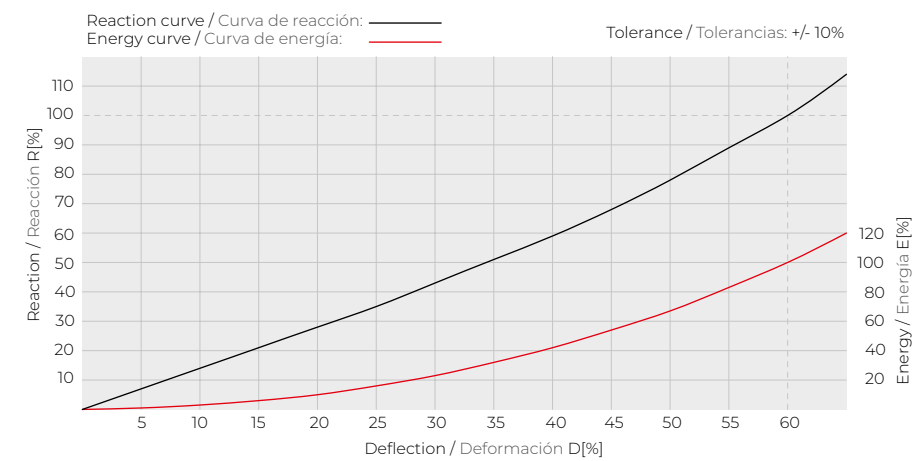

Reaction & Energy percentage values at intermediate Deflections Valores porcentuales de Reacción y Energía en Deformaciones intermedias														
Deflection / Deformación	D[%]	5	10	15	20	25	30	35	40	45	50	55	60	65
Reaction / Reacción	R[%]	7	14	21	28	35	43	51	59	68	78	89	100	114
Energy / Energía	E[%]	1	3	6	10	16	23	32	42	54	67	83	100	120

STANDARD COLOURS / COLORES ESTÁNDAR:

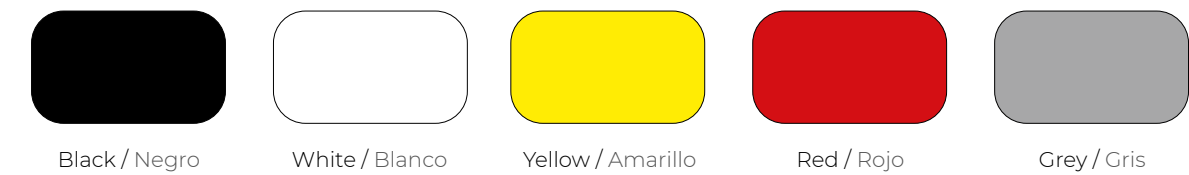

FIXING METHODS / TIPOS DE INSTALACIÓN:

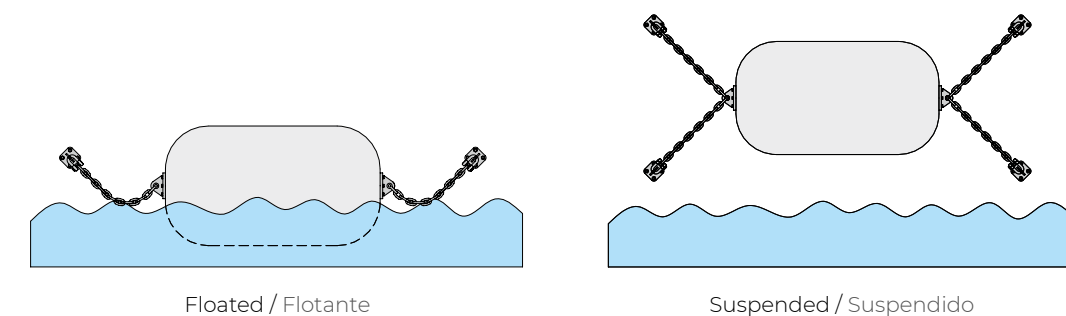

DON TYPE FENDERS

DEFENSAS TIPO DON

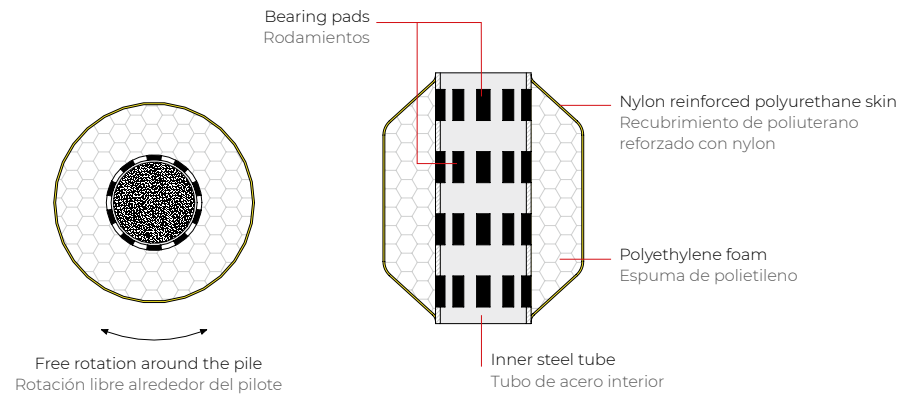

Features:

- Freely rotates
- Follow the water level
- High energy, low reaction
- Strong and durable
- Low hull pressures
- Various foam densities
- Easy installation
- Wide range of sizes
- Non-marking skin

Applications:

- Lead-in jetties
- Corner protection
- Entrance to locks and dry docks
- Turning structures
- Bridge protection
- RoRo berths

Características:

- Libre rotación
- Seguimiento de las carreras de mareas
- Gran absorción de energía, baja fuerza de reacción
- Robustas y duraderas
- Bajas presiones sobre el casco de buque
- Diferentes densidades de foam
- Instalación sencilla
- Gran rango de dimensiones
- El recubrimiento no deja marca en los cascos de buques

Aplicaciones:

- Entradas en los muelles
- Protección de esquinas
- Entradas en esclusas y diques secos
- Estructuras giratorias
- Protección de puentes
- Terminales RoRo

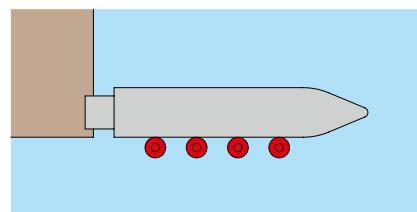

Lead-in jetty / Entrada en muelle

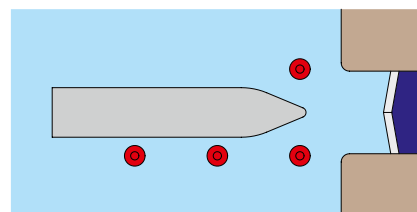

Entrance to lock / Entrada en esclusa

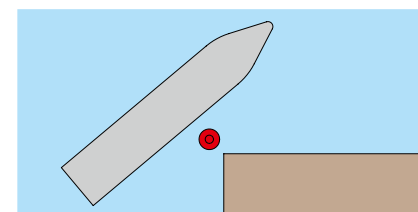

Corner protection / Protección de esquina

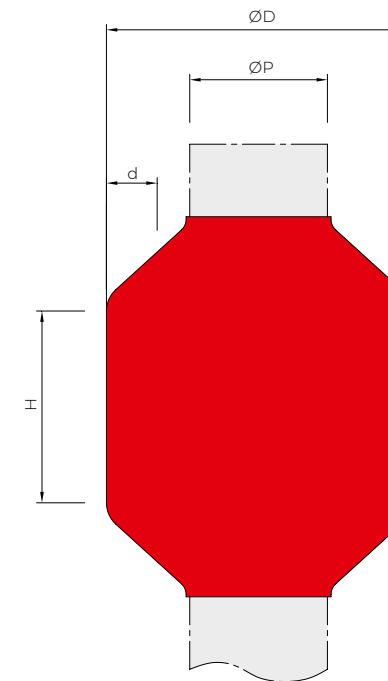

Fender Defensa	ØD	ØP	H
[]	[mm]	[mm]	[mm]
DON 1400-600	1400	600	600
DON 1400-900	1400	600	900
DON 1400-1200	1400	600	1200
DON 1400-1500	1400	600	1500
DON 1400-1800	1400	600	1800
DON 1400-2100	1400	600	2100
DON 1400-2400	1400	600	2400
DON 1500-600	1500	800	600
DON 1500-900	1500	800	900
DON 1500-1200	1500	800	1200
DON 1500-1500	1500	800	1500
DON 1500-1800	1500	800	1800
DON 1500-2100	1500	800	2100
DON 1500-2400	1500	800	2400
DON 2100-900	2100	1100	900
DON 2100-1200	2100	1100	1200
DON 2100-1500	2100	1100	1500
DON 2100-1800	2100	1100	1800
DON 2100-2100	2100	1100	2100
DON 2100-2400	2100	1100	2400

d - PE foam thickness
d - Espesor de espuma PE

Fender Defensa	ØD	ØP	H
[]	[mm]	[mm]	[mm]
DON 2300-900	2300	1200	900
DON 2300-1200	2300	1200	1200
DON 2300-1500	2300	1200	1500
DON 2300-1800	2300	1200	1800
DON 2300-2100	2300	1200	2100
DON 2300-2400	2300	1200	2400
DON 2500-900	2500	1400	900
DON 2500-1200	2500	1400	1200
DON 2500-1500	2500	1400	1500
DON 2500-1800	2500	1400	1800
DON 2500-2100	2500	1400	2100
DON 2500-2400	2500	1400	2400
DON 2700-900	2700	1500	900
DON 2700-1200	2700	1500	1200
DON 2700-1500	2700	1500	1500
DON 2700-1800	2700	1500	1800
DON 2700-2100	2700	1500	2100
DON 2700-2400	2700	1500	2400

d - PE foam thickness
d - Espesor de espuma PE

DON TYPE FENDERS

DEFENSAS TIPO DON

PERFORMANCE DATA / CARACTERÍSTICAS:

Capacity Capacidad	Standard Estándar		High Alta		Extra-High Extra alta		SuperHigh Super alta	
Size Tamaño	E	R	E	R	E	R	E	R
[]	[kNm]	[kN]	[kNm]	[kN]	[kNm]	[kN]	[kNm]	[kN]
DON 1400-600	5,5	80,4	8,9	129,4	13,5	196,1	20,2	293,2
DON 1400-900	8,3	120,6	13,4	194,2	20,3	294,2	30,3	439,8
DON 1400-1200	11,1	160,8	17,9	258,9	27,1	392,3	40,5	586,4
DON 1400-1500	13,9	201,0	22,3	323,6	33,8	490,3	50,6	733,0
DON 1400-1800	16,6	241,2	26,8	388,3	40,6	588,4	60,7	879,7
DON 1400-2100	19,4	281,5	31,3	453,1	47,4	686,5	70,8	1026
DON 1400-2400	22,2	321,7	35,7	517,8	54,1	784,5	80,9	1173
DON 1500-600	6,5	93,2	10,6	151,0	15,9	226,5	24,0	342,3
DON 1500-900	9,8	139,7	15,9	226,5	23,8	339,8	35,9	513,4
DON 1500-1200	13,0	186,3	21,1	302,0	31,7	453,1	47,9	684,5
DON 1500-1500	16,3	232,9	26,4	377,6	39,6	566,3	59,9	855,6
DON 1500-1800	19,6	279,5	31,7	453,1	47,6	679,6	71,9	1027
DON 1500-2100	22,8	326,1	37,0	528,6	55,5	792,9	83,9	1198
DON 1500-2400	26,1	372,7	42,3	604,1	63,4	906,1	95,8	1369
DON 2100-900	20,2	177,5	33,0	289,3	50,2	440,3	75,0	658,0
DON 2100-1200	27,0	236,7	44,0	385,7	66,9	587,1	100,0	877,4
DON 2100-1500	33,7	295,8	55,0	482,2	83,7	733,9	125,0	1097
DON 2100-1800	40,5	355,0	66,0	578,6	100,4	880,6	150,0	1316
DON 2100-2100	47,2	414,2	77,0	675,0	117,1	1027	175,0	1535
DON 2100-2400	54,0	473,3	87,9	771,5	133,9	1174	200,0	1755
DON 2300-900	22,6	196,1	36,9	320,7	56,3	489,4	84,4	733,5
DON 2300-1200	30,1	261,5	49,2	427,6	75,0	652,5	112,5	978,0
DON 2300-1500	37,6	326,9	61,5	534,5	93,8	815,6	140,6	1223
DON 2300-1800	45,1	392,3	73,8	641,4	112,6	978,7	168,7	1467
DON 2300-2100	52,6	457,6	86,0	748,2	131,3	1142	196,8	1712
DON 2300-2400	60,1	523,0	98,3	855,1	150,1	1305	225,0	1956
DON 2500-900	27,4	217,7	44,9	356,0	67,8	538,4	101,4	805,1
DON 2500-1200	36,6	290,3	59,8	474,6	90,4	717,8	135,3	1074
DON 2500-1500	45,7	362,8	74,8	593,3	113,1	897,3	169,1	1342
DON 2500-1800	54,9	435,4	89,7	712,0	135,7	1077	202,9	1610
DON 2500-2100	64,0	508,0	104,7	830,6	158,3	1256	236,7	1879
DON 2500-2400	73,1	580,6	119,6	949,3	180,9	1436	270,5	2147
DON 2700-900	32,2	235,4	53,1	387,4	80,5	587,4	120,6	880,6
DON 2700-1200	43,0	313,8	70,8	516,5	107,3	783,2	160,9	1174
DON 2700-1500	53,7	392,3	88,4	645,6	134,1	979,0	201,1	1468
DON 2700-1800	64,5	470,7	106,1	774,7	161,0	1175	241,3	1761
DON 2700-2100	75,2	549,2	123,8	903,8	187,8	1371	281,5	2055
DON 2700-2400	86,0	627,6	141,5	1033	214,6	1566	321,7	2348

STANDARD COLOURS / COLORES ESTÁNDAR:

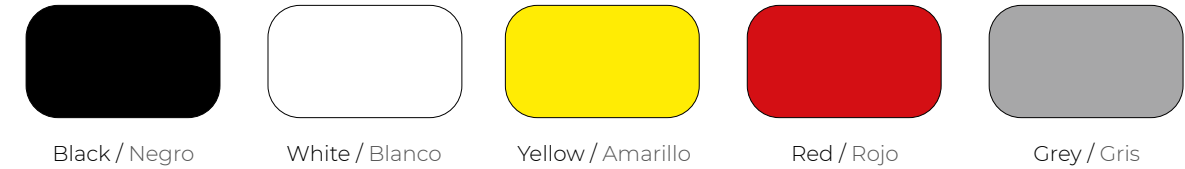

INSTALLATION / INSTALACIÓN:

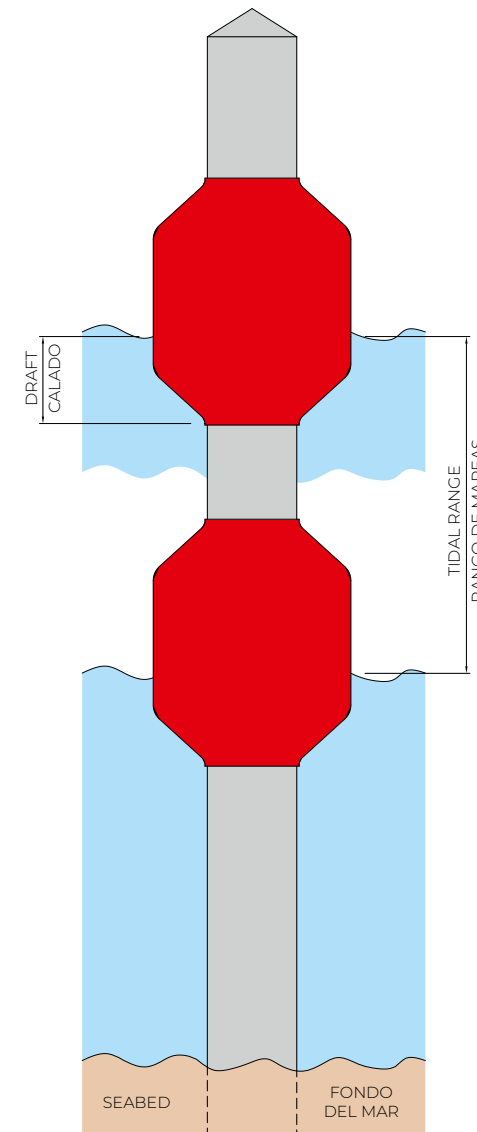

CHARACTERISTIC PERFORMANCE CURVE / CURVA CARACTERÍSTICA DE RENDIMIENTO:

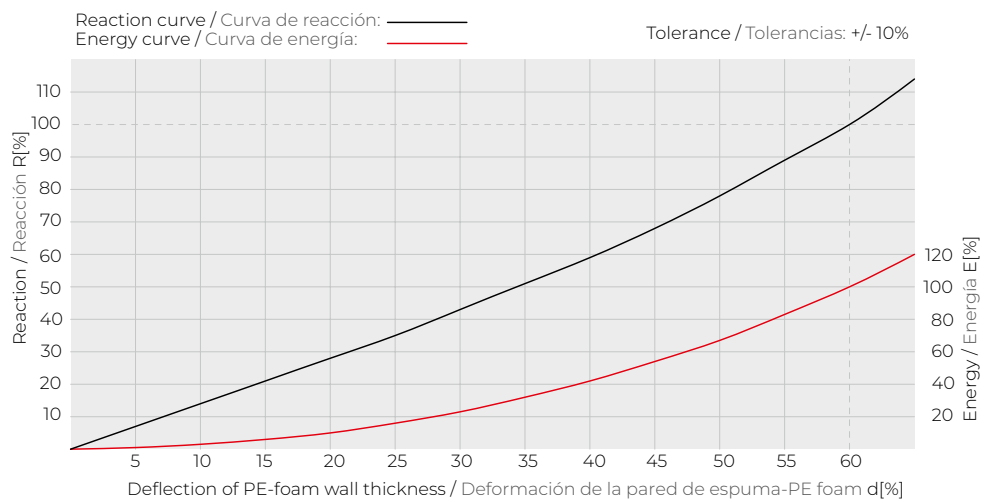

Reaction & Energy percentage values at intermediate Deflections Valores porcentuales de Reacción y Energía en Deformaciones intermedias														
Deflection / Deformación	D[%]	5	10	15	20	25	30	35	40	45	50	55	60	65
Reaction / Reacción	R[%]	7	14	21	28	35	43	51	59	68	78	89	100	114
Energy / Energía	E[%]	1	3	6	10	16	23	32	42	54	67	83	100	120

ECN TYPE FENDERS

DEFENSAS TIPO ECN

ECN 1

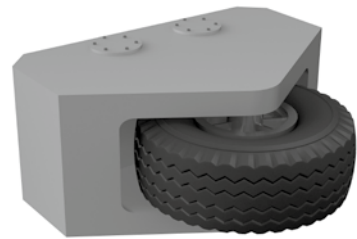

Features:

- Low rolling resistance
- Good energy absorption by rolling and deflecting
- Gentle contact face
- Maintenance-free bearings
- Single, double and triple solution
- Easy installation
- Wide range of sizes

Applications:

- Exposed corners
- Dry dock entrances and walls
- Lock approaches
- To guide the vessels through narrow passage
- All type of vessels

ECN 2

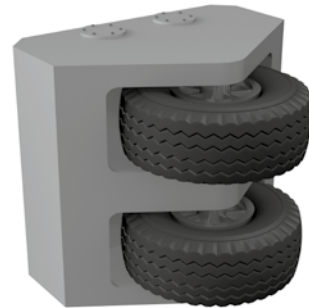

Características:

- Baja resistencia a la rodadura
- Absorción de energía por deflexión y rodadura
- Contacto suave con el casco de buque
- Rodamientos libres de mantenimiento
- Soluciones simples, dobles y triples
- Instalación sencilla
- Gran rango de dimensiones

Aplicaciones:

- Esquinas expuestas
- Entradas y muros de los diques secos
- Entradas a esclusas
- Guiado de buques en pasos estrechos
- Todo tipo de buques

ECN 3

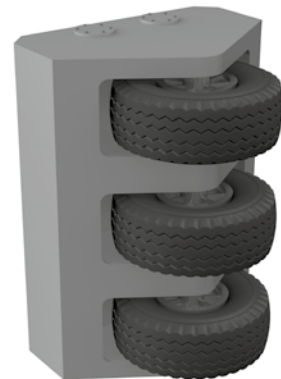

DIMENSIONS / DIMENSIONES:

ECN 1

Fender Defensa []	ØD [mm]	d [mm]	A [mm]	C [mm]	E [mm]	G [mm]	H [mm]	Anchors Anclajes [n x M]
ECN1-1080	1080	400	1700	460	900	1000	1450	6 x M30
ECN1-1300	1300	500	2000	510	1000	1200	1750	6 x M30
ECN1-1750	1750	600	2650	690	1150	1500	2200	6 x M36
ECN1-1980	1980	700	2750	760	1250	1750	2550	6 x M42
ECN1-2550	2550	925	3350	970	1600	2200	3200	6 x M48
ECN1-2900	2900	1200	4200	900	1700	2500	3750	6 x M56

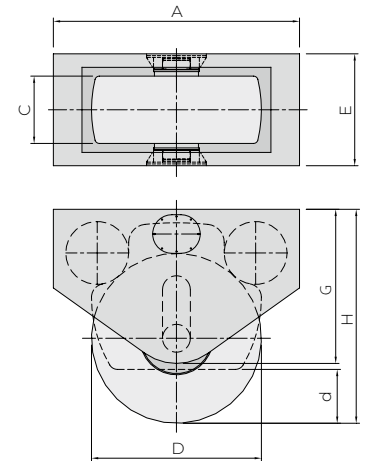

ECN 2

Fender Defensa []	ØD [mm]	d [mm]	A [mm]	C [mm]	E [mm]	G [mm]	H [mm]	Anchors Anclajes [n x M]
ECN2-1080	1080	400	1700	460	900	1000	1450	12 x M30
ECN2-1300	1300	500	2000	510	1000	1200	1750	12 x M30
ECN2-1750	1750	600	2650	690	1150	1500	2200	12 x M36
ECN2-1980	1980	700	2750	760	1250	1750	2550	12 x M42
ECN2-2550	2550	925	3350	970	1600	2200	3200	12 x M48
ECN2-2900	2900	1200	4200	900	1700	2500	3750	12 x M56

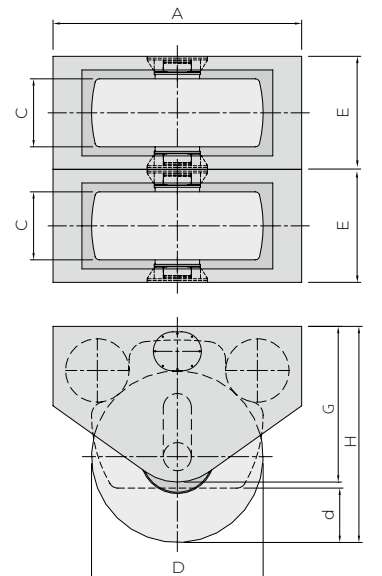

ECN TYPE FENDERS

DEFENSAS TIPO ECN

DIMENSIONS (CONTINUATION) / DIMENSIONES (CONTINUACIÓN):

ECN 3

Fender Defensa []	ØD [mm]	d [mm]	A [mm]	C [mm]	E [mm]	G [mm]	H [mm]	Anchors Anclajes [n x M]
ECN3-1080	1080	400	1700	460	900	1000	1450	18 x M30
ECN3-1300	1300	500	2000	510	1000	1200	1750	18 x M30
ECN3-1750	1750	600	2650	690	1150	1500	2200	18 x M36
ECN3-1980	1980	700	2750	760	1250	1750	2550	18 x M42
ECN3-2550	2550	925	3350	970	1600	2200	3200	18 x M48
ECN3-2900	2900	1200	4200	900	1700	2500	3750	18 x M56

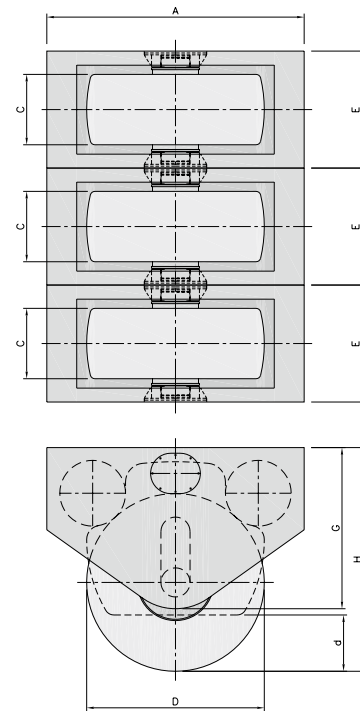

DIMENSIONAL TOLERANCES / TOLERANCIAS DIMENSIONALES:

Dimension / Dimensión	Tolerances / Tolerancias
General dimensions / Dimensiones generales	±5mm
Anchor hole spacing / Distancia entre agujeros de fijación	±4mm
Anchor hole diameter / Diámetro agujeros de fijación	±3mm

PERFORMANCE DATA / CARACTERÍSTICAS:

Fender / Defensa []	E [kNm]	R [kN]	Fender / Defensa []	E [kNm]	R [kN]	Fender / Defensa []	E [kNm]	R [kN]
ECN1-1080	33	150	ECN2-1080	66	300	ECN3-1080	99	450
ECN1-1300	61	220	ECN2-1300	122	440	ECN3-1300	181	660
ECN1-1750	100	315	ECN2-1750	200	630	ECN3-1750	300	945
ECN1-1980	220	590	ECN2-1980	440	1180	ECN3-1980	660	1770
ECN1-2550	440	920	ECN2-2550	880	1840	ECN3-2550	1320	2760
ECN1-2900	880	1300	ECN2-2900	1760	2600	ECN3-2900	2640	3900

CHARACTERISTIC PERFORMANCE CURVE / CURVA CARACTERÍSTICA DE RENDIMIENTO:

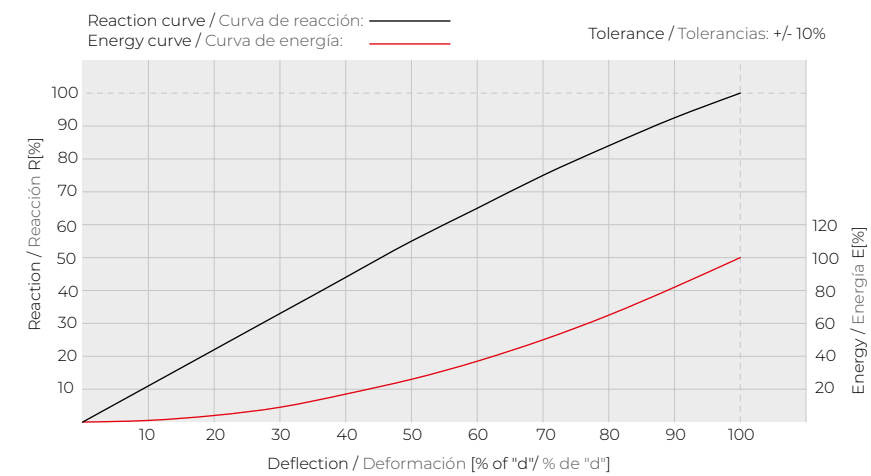

Reaction & Energy percentage values at intermediate Deflections
Valores porcentuales de Reacción y Energía en Deformaciones intermedias

Deflection / Deformación	D[% of "d"] D[% de "d"]	10	20	30	40	50	60	70	80	90	100
Reaction / Reacción	R[%]	11	22	33	44	55	65	75	84	93	100
Energy / Energía	E[%]	1	4	9	17	26	37	50	65	82	100

ECR TYPE FENDERS

DEFENSAS TIPO ECR

ECR 1

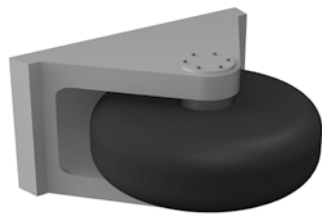

Features:

- Low rolling resistance
- Energy absorption mostly by rolling
- Gentle contact face
- Maintenance-free bearings
- Single, double and triple solution
- Easy installation
- Wide range of sizes

Applications:

- Exposed corners
- Dry dock entrances and walls
- Lock approaches
- To guide the vessel through narrow passage
- All type of vessels

ECR 2

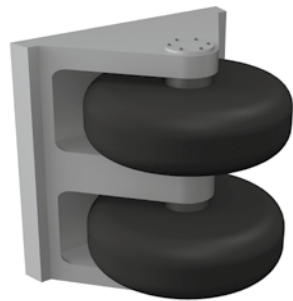

Características:

- Baja resistencia a la rodadura
- Absorción de energía mayoritariamente por rodadura
- Contacto suave con el casco de buque
- Rodamientos libres de mantenimiento
- Soluciones simples, dobles y triples
- Instalación sencilla
- Gran rango de dimensiones

Aplicaciones:

- Esquinas expuestas
- Entradas y muros de los diques secos
- Entradas a esclusas
- Guiado de buques en pasos estrechos
- Todo tipo de buques

ECR 3

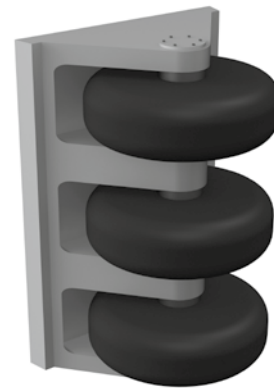

DIMENSIONS AND WEIGHTS / DIMENSIONES Y PESOS:

ECR 1

Fender Defensas []	Øc [mm]	d [mm]	A [mm]	B [mm]	C [mm]	E [mm]	F [mm]	G [mm]	H [mm]	Anchors Anclajes [n x M]	Weight Peso [kg]
ECR1-600	600	70	695	590	200	420	340	320	620	4 x M22	165
ECR1-750	750	95	870	750	250	510	430	400	775	4 x M24	390
ECR1-900	900	120	1040	900	300	610	490	480	930	4 x M30	620
ECR1-1200	1200	150	1380	1250	400	820	660	640	1240	4 x M33	1075
ECR1-1500	1500	180	1740	1550	500	1010	810	800	1550	4 x M36	1525
ECR1-1800	1800	215	2080	1800	600	1210	960	960	1860	4 x M42	1975
ECR1-2100	2100	250	2440	2200	700	1410	1110	1155	2205	4 x M48	2430
ECR1-2400	2400	285	2770	2500	800	1610	1260	1280	2480	4 x M56	2880
ECR1-2700	2700	320	3130	2900	900	1810	1410	1440	2790	4 x M60	3330
ECR1-3000	3000	360	3480	3200	1000	2010	1560	1600	3100	4 x M64	3785

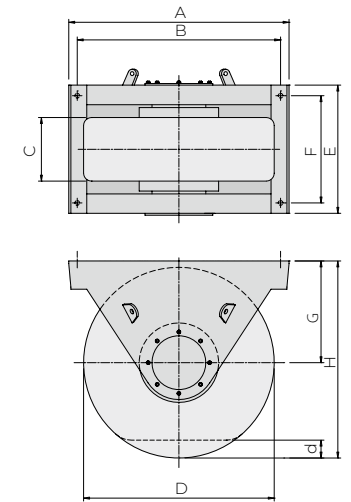

ECR 2

Fender Defensas []	Øc [mm]	d [mm]	A [mm]	B [mm]	C [mm]	E [mm]	F [mm]	G [mm]	H [mm]	Anchors Anclajes [n x M]	Weight Peso [kg]
ECR2-600	600	70	695	590	200	770	300	320	620	8 x M22	290
ECR2-750	750	95	870	750	250	935	375	400	775	8 x M24	710
ECR2-900	900	120	1040	900	300	1120	450	480	930	8 x M30	1130
ECR2-1200	1200	150	1380	1250	400	1500	600	640	1240	8 x M33	1970
ECR2-1500	1500	180	1740	1550	500	1850	750	800	1550	8 x M36	2810
ECR2-1800	1800	215	2080	1800	600	2215	900	960	1860	8 x M42	3650
ECR2-2100	2100	250	2440	2200	700	2590	1050	1155	2205	8 x M48	4495
ECR2-2400	2400	285	2770	2500	800	2950	1180	1280	2480	8 x M56	5335
ECR2-2700	2700	320	3130	2900	900	3320	1330	1440	2790	8 x M60	6175
ECR2-3000	3000	360	3480	3200	1000	3685	1470	1600	3100	8 x M64	7015

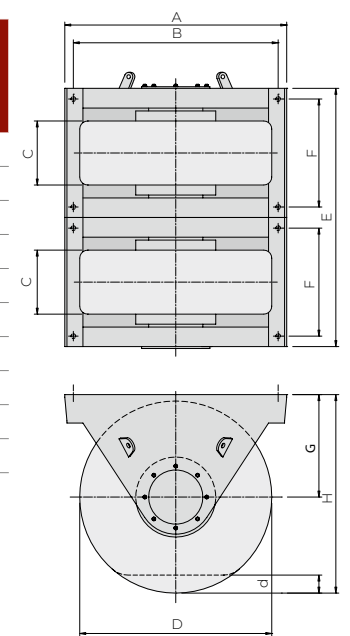

ECR TYPE FENDERS

DEFENSAS TIPO ECR

DIMENSIONS (CONTINUATION) / DIMENSIONES (CONTINUACIÓN):

ECR 3

Fender Defensa []	∅D [mm]	d [mm]	A [mm]	B [mm]	C [mm]	E [mm]	F [mm]	G [mm]	H [mm]	Anchors Anclajes [n x M]	Weight Peso [kg]
ECR3-600	600	70	695	590	200	1120	300	320	620	12 x M22	410
ECR3-750	750	95	870	750	250	1360	375	400	775	12 x M24	1025
ECR3-900	900	120	1040	900	300	1630	450	480	930	12 x M30	1640
ECR3-1200	1200	150	1380	1250	400	2180	600	640	1240	12 x M33	2870
ECR3-1500	1500	180	1740	1550	500	2690	750	800	1550	12 x M36	4100
ECR3-1800	1800	215	2080	1800	600	3220	900	960	1860	12 x M42	5325
ECR3-2100	2100	250	2440	2200	700	3770	1050	1155	2205	12 x M48	6550
ECR3-2400	2400	285	2770	2500	800	4290	1180	1280	2480	12 x M56	7780
ECR3-2700	2700	320	3130	2900	900	4830	1330	1440	2790	12 x M60	9010
ECR3-3000	3000	360	3480	3200	1000	5360	1470	1600	3100	12 x M64	10240

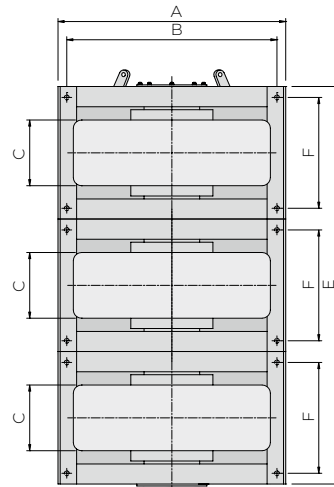

DIMENSIONAL TOLERANCES / TOLERANCIAS DIMENSIONALES:

Dimension / Dimensión	Tolerances / Tolerancias
General dimensions / Dimensiones generales	±5mm
Anchor hole spacing / Distancia entre agujeros de fijación	±4mm
Anchor hole diameter / Diámetro agujeros de fijación	±3mm

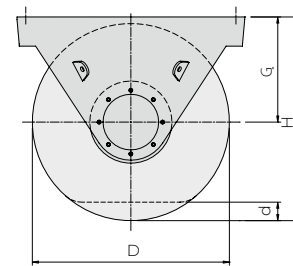

PERFORMANCE DATA / CARACTERÍSTICAS:

Fender / Defensas []	E [kNm]	R [kN]
ECR1-600	2,4	68
ECR1-750	5	105
ECR1-900	9	155
ECR1-1200	20	275
ECR1-1500	38	420
ECR1-1800	66	610
ECR1-2100	104	830
ECR1-2400	156	1095
ECR1-2700	224	1400
ECR1-3000	306	1700

Fender / Defensas []	E [kNm]	R [kN]
ECR2-600	4,8	136
ECR2-750	10	210
ECR2-900	18	310
ECR2-1200	40	550
ECR2-1500	76	840
ECR2-1800	132	1220
ECR2-2100	208	1660
ECR2-2400	312	2190
ECR2-2700	448	2800
ECR2-3000	612	3400

Fender / Defensas []	E [kNm]	R [kN]
ECR3-600	7,2	204
ECR3-750	15	315
ECR3-900	27	465
ECR3-1200	60	825
ECR3-1500	114	1260
ECR3-1800	198	1830
ECR3-2100	312	2490
ECR3-2400	468	3285
ECR3-2700	672	4200
ECR3-3000	918	5100

CHARACTERISTIC PERFORMANCE CURVE / CURVA CARACTERÍSTICA DE RENDIMIENTO:

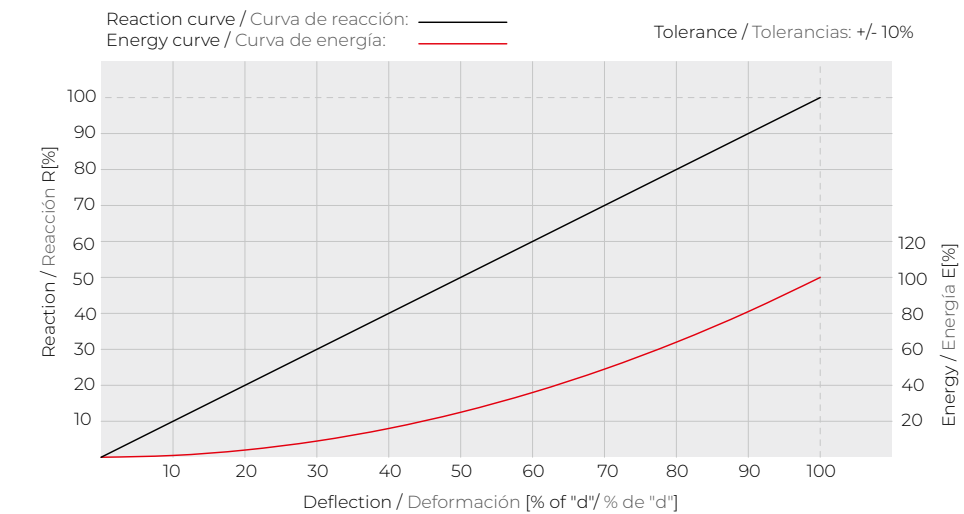

Reaction & Energy percentage values at intermediate Deflections Valores porcentuales de Reacción y Energía en Deformaciones intermedias											
Deflection / Deformación	D[% of "d"] D[% de "d"]	10	20	30	40	50	60	70	80	90	100
Reaction / Reacción	R[%]	10	20	30	40	50	60	70	80	90	100
Energy / Energía	E[%]	1	4	9	16	25	36	49	64	81	100

RF-E TYPE FENDERS

DEFENSAS TIPO RF-E



Features:

- ECR fender but with foam absorber
- Low rolling resistance
- Gentle contact face
- Maintenance-free bearings
- Easy installation
- Wide range of sizes and colours

Applications:

- Exposed corners
- Dry dock entrances and walls
- Lock approaches
- To guide the vessels through narrow passage
- All type of vessels

Características:

- Defensas de tipo ECR pero con foam de relleno
- Baja resistencia a la rodadura
- Contacto suave con el casco de buque
- Rodamientos libres de mantenimiento
- Instalación sencilla
- Gran rango de dimensiones y colores

Aplicaciones:

- Esquinas expuestas
- Entradas y muros de los diques secos
- Entradas a esclusas
- Guiado de buques en pasos estrechos
- Todo tipo de buques

DIMENSIONS / DIMENSIONES:

Fender / Defensa []	ØD [mm]	H [mm]	A [mm]	B [mm]	C [mm]	E [mm]	F [mm]	Anchors / Anclajes [n x M]
RF-E 600-600	600	600	700	450	120	1240	750	18 x M22
RF-E 600-900	600	900	700	450	120	1540	750	20 x M22
RF-E 750-750	750	750	900	525	150	1430	900	18 x M22
RF-E 750-1150	750	1150	900	525	150	1805	900	20 x M22
RF-E 900-900	900	900	1050	600	180	1690	1050	18 x M24
RF-E 900-1350	900	1350	1050	600	180	2140	1050	20 x M24
RF-E 1200-1200	1200	1200	1400	800	240	2040	1400	18 x M27
RF-E 1200-1800	1200	1800	1400	800	240	2640	1400	20 x M27
RF-E 1500-1500	1500	1500	1750	950	300	2450	1700	18 x M30
RF-E 1500-2250	1500	2250	1750	950	300	3200	1700	20 x M30
RF-E 1800-1800	1800	1800	2100	1100	360	2800	2000	18 x M39
RF-E 1800-2700	1800	2700	2100	1100	360	3700	2000	20 x M39
RF-E 2100-2100	2100	2100	2400	1300	420	3260	2350	18 x M45
RF-E 2100-3150	2100	3150	2400	1300	420	4310	2350	20 x M45
RF-E 2400-2400	2400	2400	2700	1450	480	3660	2650	18 x M52
RF-E 2400-3600	2400	3600	2700	1450	480	4860	2650	20 x M52
RF-E 2700-2700	2700	2700	3150	1600	540	4060	2950	18 x M56
RF-E 2700-4050	2700	4050	3150	1600	540	5410	2950	20 x M56
RF-E 3000-3000	3000	3000	3500	1750	600	4480	3250	18 x M56
RF-E 3000-4500	3000	4500	3500	1750	600	5980	3250	20 x M56

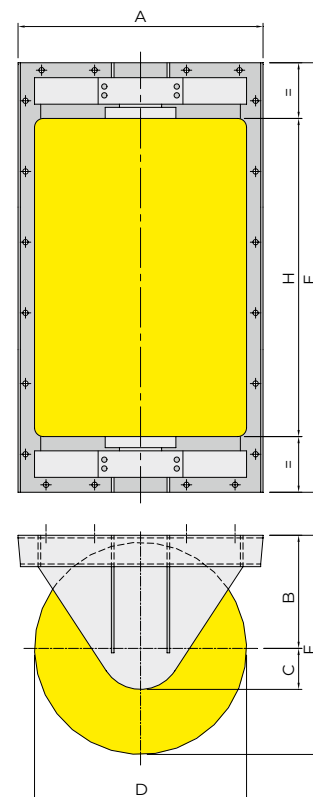

PERFORMANCE DATA / CARACTERÍSTICAS:

Capacity Capacidad	Standard Estándar		High Alta	
	E [kNm]	R [kN]	E [kNm]	R [kN]
RF-E 600-600	2,9	88,3	3,9	127,5
RF-E 600-900	3,9	127,5	5,9	196,1
RF-E 750-750	4,9	137,3	7,8	205,9
RF-E 750-1150	7,8	205,9	11,8	304,0
RF-E 900-900	8,8	196,1	13,7	294,2
RF-E 900-1350	13,7	294,2	19,6	431,5
RF-E 1200-1200	21,6	343,2	31,4	519,8
RF-E 1200-1800	32,4	519,8	47,1	774,7
RF-E 1500-1500	41,2	539,4	61,8	804,1
RF-E 1500-2250	62,8	814,0	92,2	1206

Capacity Capacidad	Standard Estándar		High Alta	
	E [kNm]	R [kN]	E [kNm]	R [kN]
RF-E 1800-1800	71,6	784,5	106,9	1157
RF-E 1800-2700	107,9	1177	159,8	1736
RF-E 2100-2100	113,8	1069	168,7	1579
RF-E 2100-3150	171,6	1599	253,0	2363
RF-E 2400-2400	170,6	1393	252,0	2059
RF-E 2400-3600	256,0	2089	378,5	3089
RF-E 2700-2700	242,2	1765	358,9	2609
RF-E 2700-4050	363,8	2648	538,4	3913
RF-E 3000-3000	332,4	2177	492,3	3217
RF-E 3000-4500	499,2	3266	739,4	4835

CHARACTERISTIC PERFORMANCE CURVE / CURVA CARACTERÍSTICA DE RENDIMIENTO:

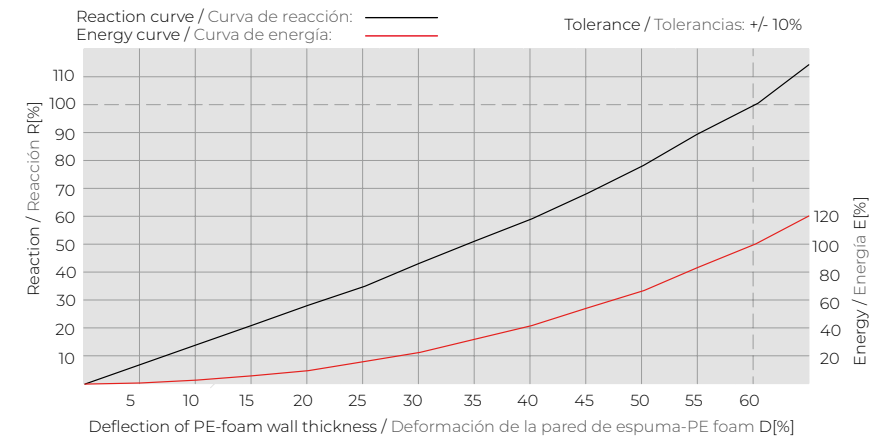

Reaction & Energy percentage values at intermediate Deflections Valores porcentuales de Reacción y Energía en Deformaciones intermedias														
Deflection / Deformación	D[%]	5	10	15	20	25	30	35	40	45	50	55	60	65
Reaction / Reacción	R[%]	7	14	21	28	35	43	51	59	68	78	89	100	114
Energy / Energía	E[%]	1	3	6	10	16	23	32	42	54	67	83	100	120

PARALLEL MOTION FENDERS SYSTEM SISTEMA DEFENSAS DE MOVIMIENTO PARALELO

In berths with large tidal ranges, frontal panels with at least two vertically installed fender units are often necessary. This solution has various disadvantages:

- for an impact near the top or bottom of the panel only the lower or upper fender unit will be compressed (all fender units must be designed for absorbing the vessel's berthing energy).
- for impacts in the middle of the panel, fender units are compressed equally. As a result, the overall fender reaction is bigger than during a top or bottom impact.
- belted vessels contacting panels near the bottom are at risk of double contact (where the top of the panel strikes the vessel's hull).

If berths have a piled dolphin structure and/or berthing vessels hulls are sensitive to double contact, parallel motion fender systems are a good solution. Parallel motion systems consist of a large frontal panel, hinged arms, torsion tube and rubber fender unit/s. The hinged arms and torsion tube guarantee the frontal panel's vertical position and control rotation. The use of two conical (TCN type) fender units mounted in a back-to-back configuration provides full rated energy absorption with 50% less reaction.

En atraques con grandes rangos de mareas, se suelen utilizar paneles frontales con, como mínimo, dos unidades de defensa instaladas verticalmente. Esta solución conlleva las siguientes desventajas:

- en caso de impactos de buques cerca de los límites superior e inferior del panel, solamente la defensa inferior o la defensa superior se comprimirá (cada unidad de defensa individual tiene que ser diseñada para absorber la totalidad de la energía que desarrolla el buque).
- en caso del impacto en la parte media del panel, las unidades de defensa se comprimen de manera igual. Como resultado, la reacción total es mayor que en el caso de impactos cerca de los límites superior e inferior.
- cuando el buque con cinturón impacta contra la parte inferior del panel, la parte superior del panel también impacta contra el buque (doble contacto).

Si la estructura de los atraques está construida a base de pilotes y/o el casco de buque es sensible al doble contacto, el sistema de defensas de movimiento paralelo es la mejor solución. Este sistema consiste en un panel frontal de gran altura, brazos articulados, tubo de torsión y unidad/es de defensa. Los brazos articulados y el tubo de torsión garantizan siempre la posición vertical de panel frontal y su rotación. El uso de dos unidades de defensa cónica (tipo TCN) instaladas en configuración "back-to-back", asegura una alta energía de absorción con 50% menor reacción.

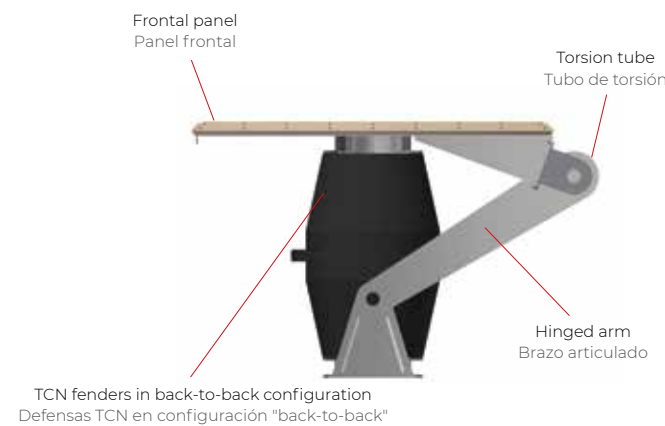

Features:

- Frontal panel without tilting
- Same performance for wide range of berthing angles
- Low reaction (back-to-back fender configuration)
- Avoids double contact with vessel
- Project specific solution

Applications:

- High to very high tidal zones
- Monopile or load sensitive berth structures
- RoRo and fast ferry berths
- Naval facilities

Características:

- Panel frontal sin inclinaciones
- Mismas características para amplio rango de ángulos de atraque
- Baja reacción (configuración "back-to-back" de defensas)
- Para evitar el doble contacto de panel frontal con el casco de buque
- Solución específica para cada proyecto

Aplicaciones:

- Rango de mareas alto o muy alto
- Monopilotes o estructuras sensibles a cargas
- RoRo y terminales de transbordadores rápidos
- Instalaciones navales

ADVANTAGE OF BACK-TO-BACK FENDER CONFIGURATION / VENTAJA DE LA CONFIGURACIÓN DE DEFENSAS "BACK-TO-BACK":

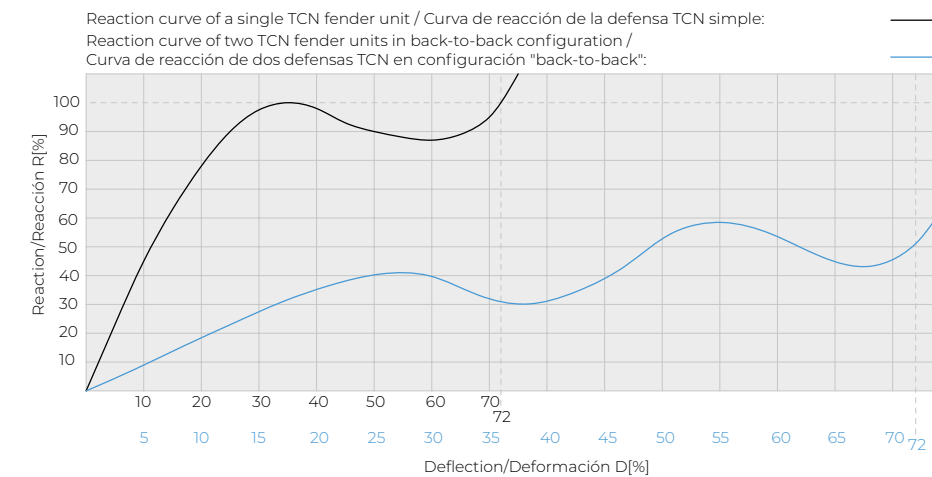

FIXING METHODS / DOS MANERAS DE INSTALAR:

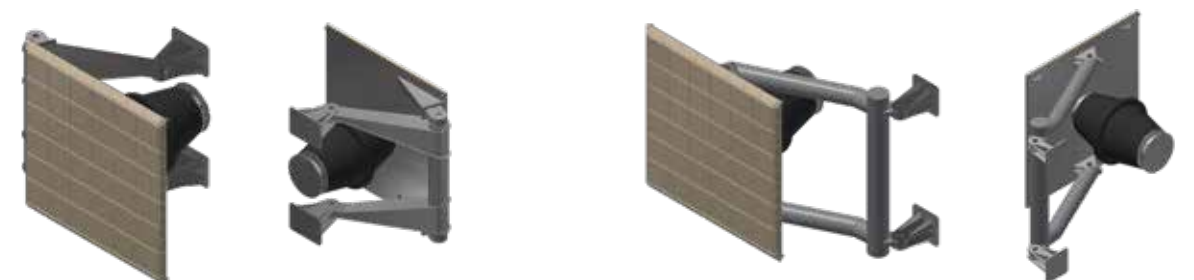

Parallel motion system (fenders and torsion arms installed on the monopile)
Sistema de movimiento paralelo (defensas y brazos de torsión instalados en el monopilote)

Parallel motion system (fenders and torsion arms separately installed)
Sistema de movimiento paralelo (defensas y brazos de torsión instalados por separado)

PROJECT SPECIFIC SOLUTION / SOLUCIONES ESPECÍFICAS PARA CADA PROYECTO:

Parallel motion fender systems are project specific; they need to be uniquely designed in order to cover all the individual vessel and berthing requirements as well as the site conditions. Contact Prosertek for further details.

Los sistemas de defensas de movimiento paralelo son específicos para cada proyecto; deben diseñarse de forma única para cubrir todos los requisitos del atraque para los diferentes tipos de buques, así como las condiciones del lugar. Póngase en contacto con Prosertek para más detalles.

PIVOT FENDERS

Fender systems for RoRo ships, Ferries and Fast ferries. Specially designed for ships with lightweight aluminium hulls that have hull protection belts and high freeboard height. The height of vessel beltings in respect to the dock varies continuously with changes in sea level (tides and waves) and by the loading status of the vessel (fully or partially loaded or unloaded). The fender system must be designed to withstand point impacts at any of the belt heights. The system has a ball joint that allows the absorption of movements in any axes. By combining the ball joint with the rubber fender (TCN, SC or IV), the necessary freedom is obtained to absorb the cyclical impacts of the moored ship.

The ball joint is fixed on the bottom edge of the quay (in the case of a continuous quay) or on the sea floor (in the case of berths made of steel piles and concrete superstructure). For Pivot fenders where the ball joint is mounted on a quay wall, it is not necessary to maintain the anchoring elements on the sea floor. The rubber fenders are located close to mean sea level, ensuring energy absorption with minimal reaction forces.

DEFENSAS PIVOTANTES

Especialmente diseñadas para buques RoRo, transbordadores (Ferries) y transbordadores rápidos (Fast ferries). Sobre todo, para buques de cascos ligeros de fabricación en aluminio que tienen cintones de protección del casco y gran altura de francobordo. La altura de cintón relativa al muelle, varía continuamente con los cambios del nivel del mar (mareas y olas) y también por la situación de carga del propio buque (buque total o parcialmente cargado o sin carga).

El sistema de defensa tiene que ser diseñado para soportar impactos puntuales en cualquiera de las alturas de los cintones. El sistema presenta una rótula inferior que permite la absorción de movimientos en cualquiera de sus ejes. La combinación de la rótula con la defensa de caucho que se instale (TCN, SC o IV) permitirá al sistema tener libertad para la absorción de los impactos cíclicos del buque atracado.

La rótula inferior se fija en el cantil del muelle (caso de muelle continuo) o en el fondo de mar cerca de los pilotes de acero (caso de muelles conformados de pilotes de acero y la superestructura de hormigón). Si el sistema de defensa se fija al cantil del muelle, no es necesario el mantenimiento de elementos de fondeo. Las defensas de caucho se deberían situar cerca de nivel medio del mar, permitiendo de esta manera la absorción de energía de los buques con mínimas fuerzas de reacción.



Features:

- Single point contact
- Low reaction
- To avoid double contact with vessel
- Safe and stable system
- Project specific solution

Applications:

- High to very high tidal zones
- RoRo and ferry berths

Características:

- Contacto puntual
- Baja reacción
- Para evitar el doble contacto con el casco de buque
- Sistema seguro y estable
- Solución específica para cada proyecto

Aplicaciones:

- Rango de mareas alto o muy alto
- RoRo y terminales de transbordadores



PROJECT SPECIFIC SOLUTION / SOLUCIONES ESPECÍFICAS PARA CADA PROYECTO:

As with Parallel Motion fender systems, Pivot fender systems are project specific; they need to be uniquely designed in order to cover all the individual vessel and berthing requirements as well as the site conditions. Contact Prosertek for further details.

Al igual que los sistemas de defensas de movimiento paralelo, los sistemas de defensas pivotantes son específicos de proyecto; deben diseñarse de forma única para cubrir todos los requisitos de atraque y buques individuales, así como las condiciones del lugar. Póngase en contacto con Prosertek para obtener más detalles.

RUBBER COMPOUNDS

COMPUESTOS DE CAUCHO

Rubber compounds are raw materials to produce rubber fender units. They are complex chemical materials, whose main ingredients are:

- polymer or blend of polymers, for giving visco-elastic characteristics to rubber fenders. Most common are Natural Rubber (NR) and Styrene-Butadiene Rubber (SBR).
- fillers, for reinforcing of polymer/s. Most common are carbon black and silicas.
- plasticizers, for improving processability and vulcanizate elasticity. Most common are mineral and synthetic oils.
- crosslinking agents, for establishing of long chains. Most common is sulphur.
- activators, for activation of crosslinking. Most common is zinc oxide (ZnO).
- accelerators, for controlling of velocity of the vulcanization process.
- protectors/antioxidants, for increasing the temperature and ozone resistance

In the below table, main characteristics of most common used polymers (NR and SBR) are shown. It is clear that rubber compound needs to be adjusted to the intended use of rubber fenders (geographical location, kinetic energy to be absorbed, vessels' velocities, harbour water characteristics, etc.). In this catalogue, values for velocity factors and temperature factors are given for the most common used rubber compound (blend of natural and styrene-butadiene rubber).

Good definition of rubber compounds adds value to ports by increasing the fender systems service life, minimising maintenance requirements and reducing the risk of incidents and accidents.

Los compuestos de caucho son la materia prima que se utiliza para la producción de las defensas de caucho. Se trata de materiales complejos, cuyos principales componentes son:

- polímero o mezcla de polímeros, para la obtención de las características viscoelásticas. Los más comunes son el caucho natural (NR) y el caucho estireno-butadieno (SBR).
- elementos de relleno, para el refuerzo de los polímeros. Los más comunes son el negro de humo y las sílices.
- plastificantes, para la mejora de la procesabilidad y de la elasticidad tras la vulcanización. Los más comunes son los aceites minerales y sintéticos.
- agentes de reticulación, para obtener las cadenas interiores más largas. El más común es el azufre.
- activadores, para la activación del proceso de reticulación. El más común es el óxido de zinc (ZnO).
- aceleradores, para el control de la velocidad del proceso de vulcanización.
- protectores/antioxidantes, para el aumento de la resistencia a la influencia del medio ambiente (temperatura y ozono).

La tabla que se presenta a continuación contiene las principales características de los polímeros NR y SBR. Está claro que la buena definición del compuesto de caucho a utilizar depende del uso previsto de la defensa de caucho (ubicación geográfica, energía cinética a absorber, velocidades de los buques, características del agua en el puerto, etc.). En este catálogo los valores que se representan relativos a los factores de velocidad y de temperatura corresponden al compuesto de caucho más usado (la mezcla de cauchos natural y estireno-butadieno).

Una adecuada definición de los compuestos de caucho añade valor a los puertos al aumentarse la vida útil de los sistemas de defensas, minimizando su mantenimiento y reduciéndose el riesgo de incidentes y accidentes.

Characteristic / Característica	Natural rubber / Caucho natural	Synthetic rubber* / Caucho sintético*
Elasticity / Elasticidad	High / Alta	Medium / Media
Viscosity / Viscosidad	Low / Baja	High / Alta
Tensile Strength / Resistencia a tracción	High / Alta	Medium / Media
Energy Absorption - Reaction Force Ratio / Ratio Absorción de energía - Fuerza de reacción	Good / Buena	Medium / Media
Velocity Influence / Influencia de la velocidad	Low / Baja	High / Alta
Temperature Influence / Influencia de la temperatura	Low / Baja	High / Alta
Angle Influence / Influencia del ángulo	Good / Buena	Good / Buena
Ageing Resistance / Resistencia al envejecimiento	Medium / Media	Good / Buena
Processability / Procesabilidad	Low / Baja	Medium / Media
Manufacturing Tolerance / Tolerancias de fabricación	Medium / Media	Good / Buena
Physical Fatigue / Fatiga mecánica	Good / Buena	Medium / Media
Resistance to Chemical Deterioration / Resistencia al deterioro químico	Medium / Media	Good / Buena
Abrasion Resistance / Resistencia a la abrasión	Medium / Media	Good / Buena
Flame Resistance / Resistencia al fuego	Medium / Media	Good / Buena

* SBR (Styrene-Butadiene Rubber) is most common used synthetic rubber for marine fender production
* SBR (caucho estireno-butadieno) es el caucho sintético más usado en fabricación de las defensas marinas

PERFORMANCE DATA / CARACTERÍSTICAS:

Standard test / Ensayos estándares:

Property / Características []	Testing standard / Norma de ensayo		Test conditions/ Condiciones de ensayo []	Requirement Requisito []
	ISO []	Others / Otros []		
Tensile strength / Resistencia a la tracción	ISO 37	ASTM D 412 Die C UNE ISO 37 AS 1683.11 JIS K 6251	Before ageing / Antes del envejecimiento After ageing* / Después del envejecimiento*	≥ 16MPa ≥ 12,8MPa
Elongation at break / Alargamiento a la rotura	ISO 37	ASTM D 412 Die C UNE ISO 37 AS 1683.11 JIS K 6251	Before ageing / Antes del envejecimiento After ageing* / Después del envejecimiento*	≥ 350% ≥ 280%
Hardness / Dureza	ISO 7619-1	ASTM D 2240 UNE ISO 7619-1 AS 1683.15.2 JIS K 65253-3	Before ageing / Antes del envejecimiento After ageing* / Después del envejecimiento*	≤ 78° Sh A ≤ (original +8°) Sh A
Compression Set / Set de compresión	ISO 815-1	ASTM D 395 Method B UNE ISO 815-1 AS 1683.13 Type 1 JIS K 6262	22h @ 70° C	≤ 30%
Tear Resistance / Resistencia al desgarro	ISO 34-1	ASTM D 624 Die B UNE ISO 34-1 AS 1683.12 JIS K 6252-1	Before ageing / Antes del envejecimiento	≥ 70kN/m
Ozone Resistance / Resistencia al ozono	ISO 1431-1	ASTM D 1149 UNE ISO 1431-1 AS 1683.24 JIS K 6259-1	50pphm @ 20% strain, 40°C, 100h	No cracks / Sin grietas
Abrasion** / Abrasión**	ISO 4649	ASTM D 5963 UNE ISO 4649		≤ 100mm ³
Bond Strength / Fuerza de adhesión	ISO 813	ASTM D 429 Method B UNE 53565 AS 1683.14.1 JIS K 6256	Rubber to Steel / Caucho-acero	≥ 7N/mm

* Ageing acc. ISO 188 (ASTM D 573) 96h @ 70°C / * - Envejecimiento s/ ISO 188 (ASTM D 573) 96h @ 70°C

** In case of fender units with direct contact with the vessel's hull / * - Para el supuesto de defensas con contacto directo con el casco de buque

Optional test / Ensayos opcionales:

Property / Características []	Testing standard / Norma de ensayo		Test conditions/ Condiciones de ensayo []	Requirement Requisito []
	ISO []	Others / Otros []		
Seawater resistance / Resistencia al agua del mar	ISO 1817	ASTM D 471 UNE ISO 1817 AS 1683.23 JIS K 6258	28days @ 95°C	Change in hardness: < ±10° Sh A Change in volume: < +10% / -5%
Dynamic Fatigue / Fatiga dinámica	ISO 132	ASTM D 430 Method B UNE 53513 AS 1683.18 JIS K 6260	15000cycles	Grade 0-2

On demand with extra cost / Bajo demanda con coste extra



INTRODUCTION

INTRODUCCIÓN

Rubber fender systems typically comprise a number of critical accessories. In addition to absorbing a vessel's kinetic energy, other requirements such as preventing damage to vessels' hulls or limiting the movements of the fenders themselves become critical to the safe functioning of the system and the uninterrupted operation of the berths on which they are installed. The most common accessories are:

- anchors which are suitable for the type of connection structure (for example concrete)
- steel frontal panels
- low friction ultra-high molecular weight polyethylene pads (UHMW-PE)
- restraint chains (for weight, tension and shear forces)
- special adaptor brackets or frames to allow connection of fenders to berthing structures

Los sistemas de defensas marinas son mucho más que las propias unidades de defensa de caucho. Muchos sistemas tienen que satisfacer, además de la absorción de energía cinética, otros requerimientos como, por ejemplo, el no dañar el casco del buque y/o limitar los movimientos (en una palabra, proteger) de las unidades de defensas. Estos elementos, denominados accesorios, tienen una gran importancia dentro del conjunto de sistemas de defensas. Los accesorios más comunes son:

- anclajes
- paneles metálicos frontales
- placas de polietileno de ultra alto peso molecular (PE-UAPM)
- sistemas de cadenas para restricción de movimientos
- adaptadores especiales para permitir conexión de las defensas a las estructuras de atraque

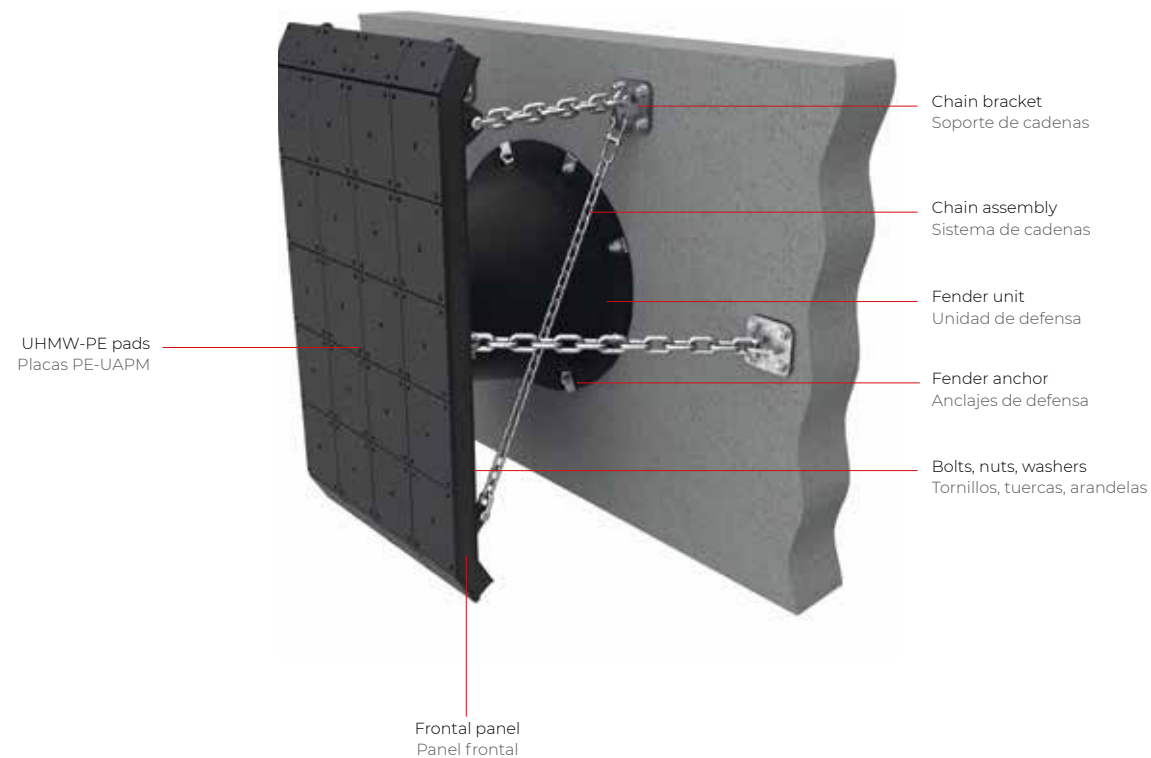

ANCHORS FOR FENDER FIXING

ANCLAJES PARA FIJACIÓN DE DEFENSAS

Cast-in anchors for new concrete / Anclajes para embeber en hormigón nuevo:

Material / Material	Standard Norma	Grade Grado	Yield Strength Límite elástico [MPa]	Tensile strength Resistencia a tracción [MPa]
HDG Carbon Steel / Acero al carbono GC	ISO 898*	4.8*	320	400
HDG Carbon Steel / Acero al carbono GC	EN 10025*	S355J2*	355	510
Stainless Steel / Acero inoxidable	EN 10088*	1.4401*	240	540

* or equivalent / o equivalente

HDG - Hot Dip Galvanised acc. ISO 1461 / GC - Galvanizado en caliente según ISO 1461

Size Tamaño [mm]	ØA [mm]	B [mm]	L [mm]	Weight Peso [kg]
M18	28	45	150	1,0
M22	32	60	175	1,4
M24	38	70	175	1,8
M30	38	80	200	2,5
M36	50	90	200	4,3
M42	56	90	250	8,0
M48	60	90	250	9,0
M52	70	100	250	12,0
M56	75	120	300	17,0
M60	80	120	350	21,0
M64	80	140	350	23,0

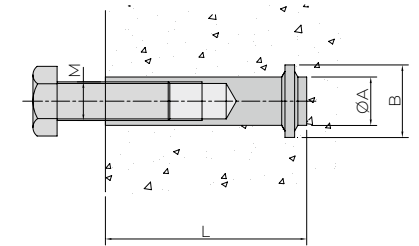

Anchors for existing concrete / Anclajes para hormigón existente:

Material / Material	Standard Norma	Grade Grado	Yield Strength Límite elástico [MPa]	Tensile strength Resistencia a tracción [MPa]
HDG Carbon Steel / Acero al carbono GC	ISO 898*	4.8*	320	400
HDG Carbon Steel / Acero al carbono GC	EN 10025*	S355J2*	355	510
Stainless Steel / Acero inoxidable	EN 10088*	1.4401*	240	540

* or equivalent / o equivalente

HDG - Hot Dip Galvanised acc. ISO 1461 / GC - Galvanizado en caliente según ISO 1461

Size Tamaño [mm]	A [mm]	B [mm]	ØC* [mm]	L [mm]	Weight Peso [kg]
M18	50	200	26	250	0,7
M22	50	200	30	250	1,0
M24	65	200	34	265	1,2
M30	70	300	40	370	2,2
M36	80	300	47	380	3,5
M42	105	350	52	455	5,7
M48	110	450	62	560	9,0
M52	110	550	62	660	12,0
M56	130	650	67	790	16,5
M60	155	700	72	855	21,0
M64	155	750	77	905	25,0

* drilled hole for resin / diámetro de agujero para la resina

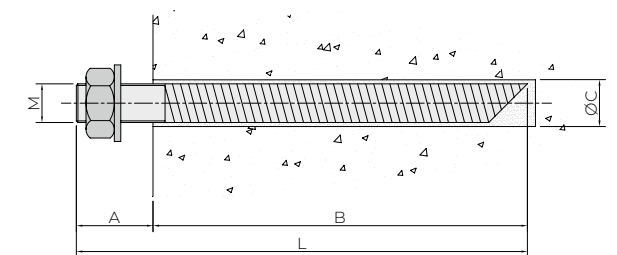

FRONTAL PANELS

PANELES FRONTALES

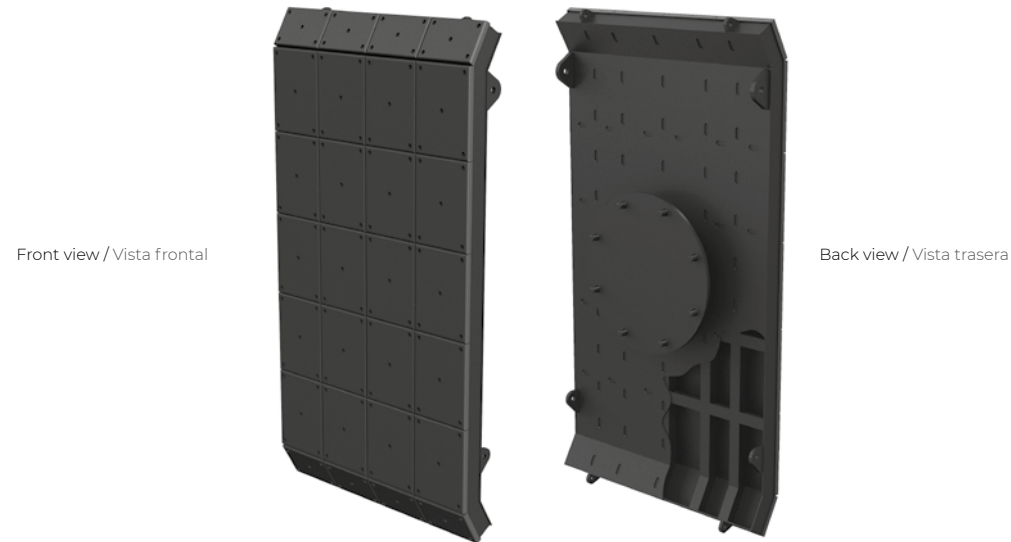

Features:

- Closed box structure
- Internal reinforcements
- With or without bevels and/or chamfers
- Points for rubber fender connection
- Studs for UHMW-PE pads
- Pad-eyes for chains
- Lifting lugs
- Test for water tightness

Características:

- Estructura de cajón cerrado
- Refuerzos interiores
- Con o sin bisel y/o chaflanes
- Puntos para la fijación de defensa de caucho
- Pernos para el amarre de las placas PE-UAPM
- Orejetas para el amarre de cadenas
- Orejetas para la manipulación y el montaje
- Ensayo de estanqueidad

STANDARD MATERIALS FOR THE STEEL FRONTAL PANELS /

MATERIALES ESTANDARES PARA LA FABRICACIÓN DE PANELES FRONTALES DE ACERO:

Standard / Norma	Steel quality Tipo de acero	Yield Strength Límite elástico Min [MPa]	Tensile strength Resistencia a la tracción Min [MPa]	Temperature of Charpy impact test Temperatura de ensayo del impacto Charpy [°C]
EN 10025*	S235JR (1.0038)	235	360	20
	S275JR (1.0044)	275	420	20
	S355J0 (1.0553)	355	510	0
	S355J2 (1.0570)	355	510	-20
GB/T 700*	Q235B	235	375	20
	Q275B	275	490	20
GB/T 1591*	Q345B	345	470	20
	Q345C	345	470	0
	Q345D	345	470	-20
GB/T 1591*	Q355B	355	510	20
	Q355C	355	510	0
	Q355D	355	510	-20

* or equivalent / o equivalente

HDG – Hot Dip Galvanised acc. ISO 1461 / CC - Galvanizado en caliente según ISO 1461

STEEL PLATE THICKNESS / ESPESORES DE ACERO PARA EL DISEÑO Y LA FABRICACIÓN:

Corrosion exposure / Exposición a la corrosión	Steel thickness* / Espesor acero*
Both faces exposed / Ambas caras expuestas	≥ 12mm
One face exposed / Una cara expuesta	≥ 9mm
Without exposure / Sin exposición	≥ 8mm

* in accordance with PIANC 2002 recommendations

* de acuerdo con las recomendaciones PIANC 2002

Standard coating protection systems for the steel frontal panels / Sistemas de anticorrosión estándar para los paneles frontales de acero:

Paint system* Esquema de pintado []	Surface preparation Preparación superficie []	Primary coat Imprimación		Intermediate coat Capa intermedia		Intermediate coat Capa intermedia		Finish coat Capa final		Total DFT** EPS** total [µm]
		Paint Pintura []	DFT** EPS** [µm]	Paint Pintura []	DFT** EPS** [µm]	Paint Pintura []	DFT** EPS** [µm]	Paint Pintura []	DFT** EPS** [µm]	
C5 (VH) ISO 12944	Sa 2,5	Hempadur Avantguard 750	≥60	Hempadur Mastic 45880	≥180			Hempathane HS 55610***	≥80	≥320
Im1 / Im2 ISO 12944	Sa 3	Hempadur 15570	≥100	Hempadur Quattro XO 17870	≥350					≥450
Im1 / Im2 + antifouling ISO 12944	Sa 3	Hempadur 15570	≥100	Hempadur Quattro XO 17870	≥350	Hempadur 45182	≥75	Antifouling Olympic 72950****	≥125	≥650
Splash zone Norsok M501	Sa 2,5	Hempadur 35560	≥300	Hempadur 35560	≥300					≥600
Splash zone + antifouling Norsok M501	Sa 2,5	Hempadur 35560	≥300	Hempadur 35560	≥300	Hempadur 45182	≥75	Antifouling Olympic 72950****	≥125	≥800

* Hempel's paint systems or equivalent / Sistema de pintado de Hempel o equivalente

** DFT (Dry Film Thickness) / EPS (Espesor de la Película Seca)

*** Standard finish color Black RAL 9005 (other finish colors available upon request) / color acabado estándar Negro RAL 9005 (otros colores disponibles bajo demanda)

**** Standard finish color Red b51110 (other finish colors available upon request) / color acabado estándar Rojo b51110 (otros colores disponibles bajo demanda)

CATHODIC PROTECTION FOR STEEL FRONTAL PANELS / PROTECCIÓN CATÓDICA DE LOS PANELES FRONTALES DE ACERO:

Sacrificial galvanic anodes are used for cathodic protection against corrosion of steel frontal panels which are partially or totally submerged in water. Sacrificial galvanic anodes are metallic alloys, composed of zinc or aluminium. The material of these alloys is a less noble metal than that which is used in the steel frontal panels, leading them to protect the frontal panels by absorbing all corrosion. The protective system consists of galvanic anode (material to be sacrificed), galvanic cathode (material to be protected) and an electrolyte, such as water, (material permitting the circulation of the ions). The corrosion occurs only on the galvanic anode, which is sacrificed, thereby protecting the metallic structure. In order to function correctly, the galvanic anode must be partially, or totally submerged in water.

El ánodo de sacrificio es la parte de sistema que se utiliza para la protección contra la corrosión de los paneles frontales metálicos parcial o totalmente sumergidos en agua. Los ánodos de sacrificio son fabricados a base de una aleación metálica, habitualmente aleación de zinc o de aluminio, que al ser un metal menos noble que el acero de panel frontal, se "sacrifica" polarizándose en él la oxidación. El sistema consiste en un ánodo (material a sacrificar), un cátodo (material a proteger) y un electrolito (agua) para la circulación de los iones. De esta manera la corrosión se produce solamente en la aleación metálica del ánodo, causando su desgaste (sacrificio) preservando la estructura metálica a proteger. Para que el ánodo de sacrificio trabaje de manera más eficiente, el mismo debe de estar el máximo tiempo sumergido en el agua.

UHMW-PE PADS

PLACAS PE-UAPM (POLIETILENO DE ULTRA ALTO PESO MOLECULAR)

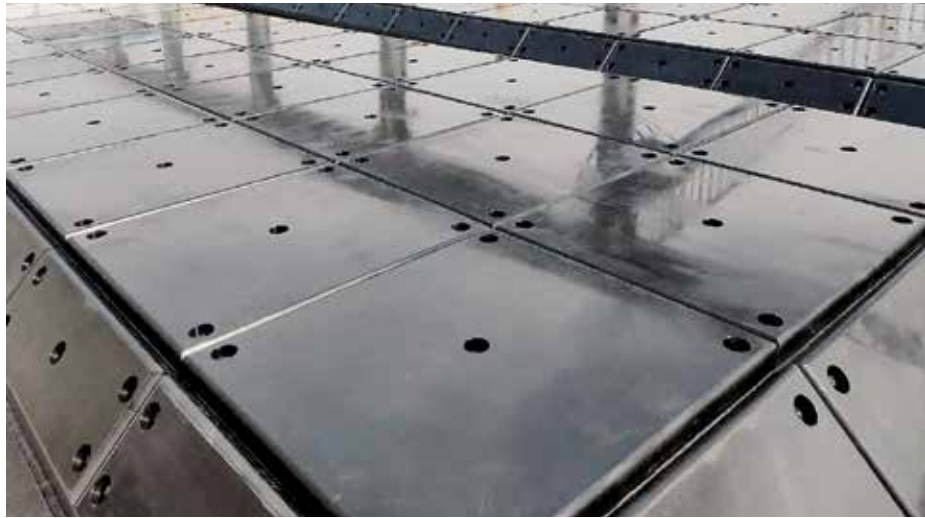

Features:

- Very low friction coefficient ($\mu < 0,2$)
- Good abrasion resistance
- UV and ozone resistant
- Resistant to cracking
- Recyclable
- Wide range of thicknesses

Características:

- Muy bajo coeficiente de fricción ($\mu < 0,2$)
- Buena resistencia a la abrasión
- Resistentes al ozono y rayos UV
- No se agrietan
- Reciclables
- Gran rango de espesores

Applications:

- Face pads for frontal panels
- Face pads for IV and SVA-P fender units

Aplicaciones:

- Placas para paneles frontales
- Placas frontales para defensas tipo IV y SVA-P

MECHANICAL PROPERTIES / PROPIEDADES MECÁNICAS:

Property / Propiedad	Testing standard Norma de ensayo	Unit Unidad	Typical values / Valores típicos	
			Virgin / Virgen	Regenerated / Regenerado
Density / Densidad	ISO 1183-1 ASTM D792	g/cm ³	0,925-0,95	0,94-0,95
Yield Strength / Límite elástico	ISO 527-1 ASTM D638	MPa	≥ 16	≥ 16
Tensile Strength / Resistencia a Tracción	ISO 527-1 ASTM D638	MPa	≥ 28	≥ 28
Elongation at Break / Alargamiento a la rotura	ISO 527-1 ASTM D638	%	≥ 50 ≥ 300	≥ 50 ≥ 300
Charpy Impact Strength / Resistencia al impacto charpy	ISO 11542-2	kJ/m ²	> 100	> 100
Hardness / Dureza	ISO 868; ASTM D2240	° Sh D	> 62	> 63

STANDARD COLOURS / COLORES ESTÁNDAR:

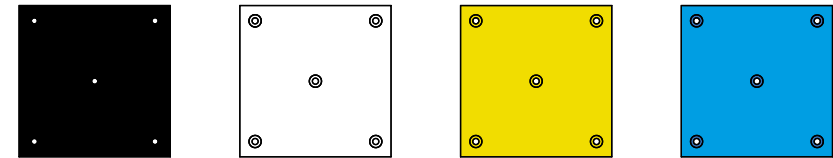

Black / Negro White / Blanco Yellow / Amarillo Light blue / Azul claro

* Other colours available upon request
* Otros colores disponibles bajo pedido

STANDARD THICKNESSES AND FIXING BOLTS / ESPESORES Y TORNILLOS DE FIJACIÓN ESTÁNDAR:

Thickness T / Espesor T [mm]	Metrics M / Métrica M [Mnn]
30	M16
40	M16
50	M16
60	M20
70	M20
80	M20
90	M24
100	M24

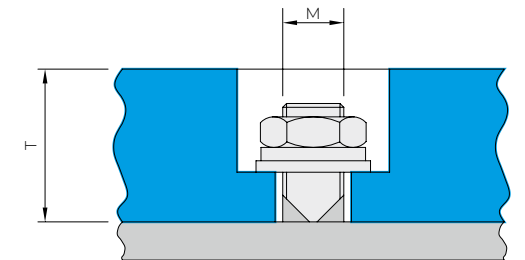

* Other thicknesses available upon request
* Otros espesores disponibles bajo demanda

UHMW-PE PADS FIXINGS / TORNILLERÍA PARA FIJACIÓN DE PLACAS PE-UAPM:

Stainless Steel EN 10088 Grade 1.4401 or equivalent / Acero inoxidable EN 10088 Grado 1.4401 o equivalente.

LARGE PADS VS SMALL PADS / PLACAS DE GRAN TAMAÑO VERSUS PLACAS DE PEQUEÑO TAMAÑO:

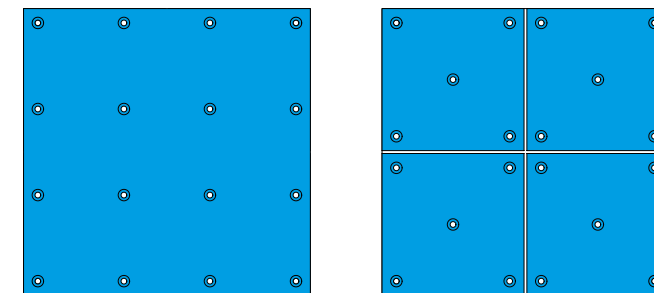

Large pads are more robust and heavier but small pads are easier and cheaper to replace.
Las placas grandes son más robustas y pesadas, pero las placas pequeñas son más fáciles y económicas de reemplazar.

CHAIN ASSEMBLIES

SISTEMAS DE CADENAS

Chain assemblies make the marine fender systems more robust by limiting their movements and deformations. Most common chain assemblies are:

- weight support chains. Fender units are capable to support certain weights of frontal frames. However, in cases when the frontal frames weight exceeds the maximum weight supported by the fender units it is necessary to use weight support chains.
- tension chains. These chains are necessary when forces which lead to abnormal compression or elongation of the rubber fender units exist. For example: to avoid excessive deformations of the rubber fender unit/s during low level vessel impacts exist.
- shear chains. These chains are used to limit the side-ways movement of the fender system and to limit excessive deformations of the rubber fender units when shear forces exist.

Los sistemas de cadenas permiten que los sistemas de defensas marinas sean más robustos restringiendo sus movimientos y deformaciones. Los sistemas de cadenas más usuales son:

- cadenas de sustentación. Las propias unidades de defensas son capaces de soportar cierto peso de los paneles frontales. En los casos en los que el peso de los paneles frontales sobrepase el peso máximo que pueden soportar las unidades de defensas es necesario usar las cadenas de sustentación.
- cadenas de tracción. Son necesarias cuando existen fuerzas que causan compresiones y/o elongaciones anormales de las unidades de defensas.
- cadenas de esfuerzo cortante, se usan para restringir los movimientos de los sistemas de defensas y evitar las deformaciones excesivas de las unidades de defensas cuando existen fuerzas cortantes.

Chain assemblies consist of chains, shackles, tensioners, brackets or "U" shape anchors. Not every of these elements are part of every chain assembly. Usually weight support chain assemblies have chain, shackle and tensioner components. Tension and shear chain assemblies have chain (with open or stud links) and shackles. Any chain assembly can be fixed to a berth structure by using brackets with anchors or "U" shape anchors.

It is good practice to protect the elements of chain assemblies by Hot Dip Galvanising (HDG).

Los sistemas completos de cadenas consisten en cadenas, grilletes, tensores y soportes o anclajes en "U". En ocasiones, no todos estos elementos forman parte de todos los sistemas de cadenas. Por lo general los sistemas de cadenas de sustentación tienen la cadena, grillete y tensor, mientras que los sistemas de cadenas de tracción y de esfuerzo cortante tienen la cadena y grilletes. Cualquier sistema de cadenas se puede fijar a la estructura de atraque usando los soportes o anclajes en "U".

Es buena práctica proteger los elementos de los sistemas de cadena mediante galvanizado en caliente (GC).

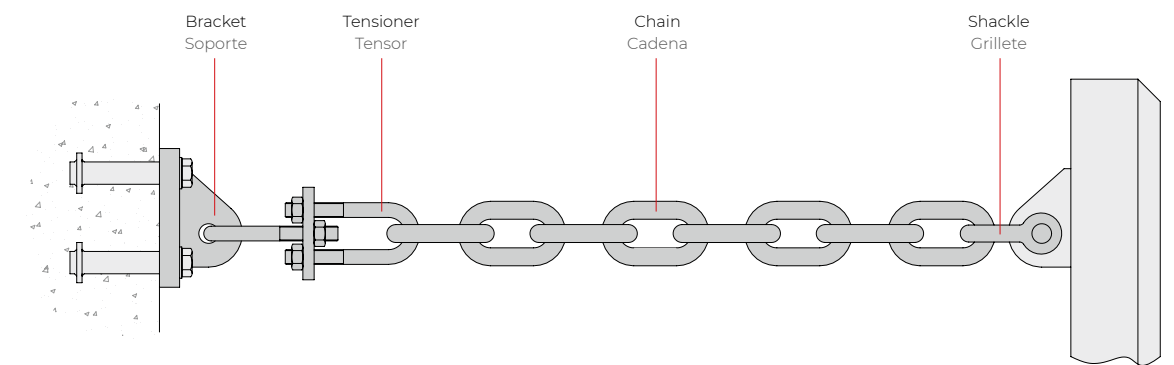
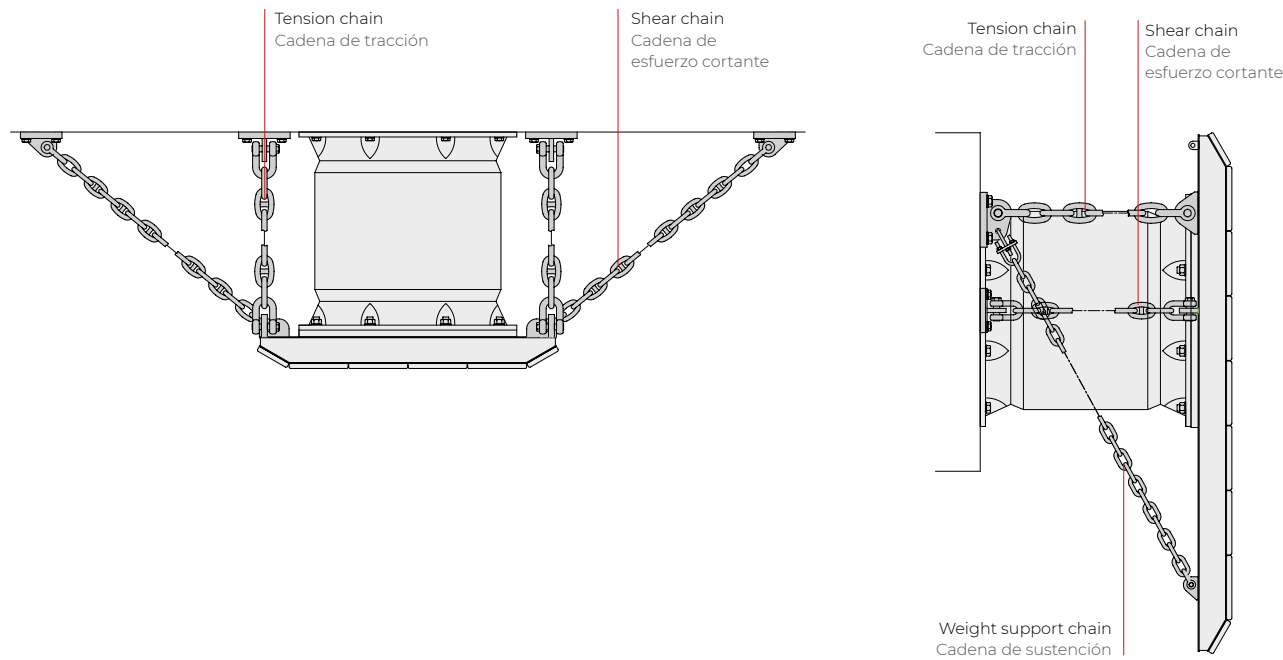

Chain assembly with bracket and anchors to be embedded into new concrete, and tensioner / Sistema de cadena con soporte con anclajes para hormigón nuevo y tensor

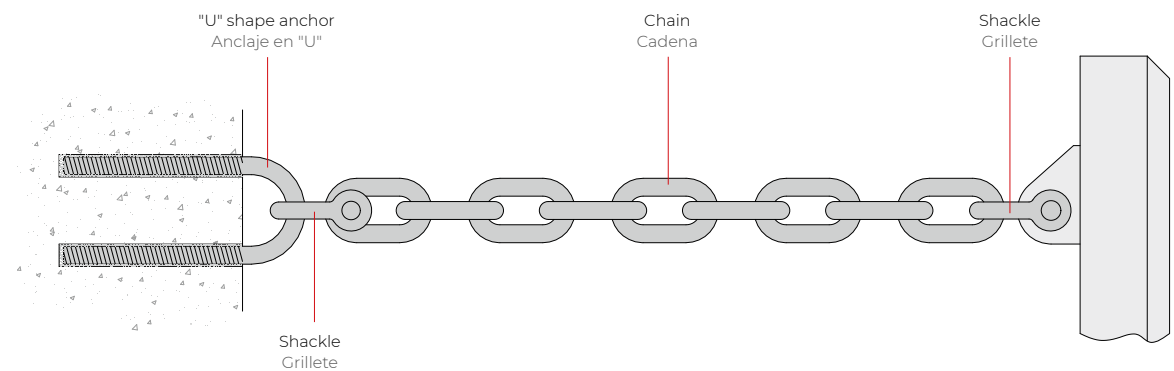

Chain assembly with "U" shape anchor for existing concrete and shackles / Sistema de cadena con anclaje en "U" para hormigón existente y grilletes

BRACKETS

SOPORTES

Single Chain Brackets / Soportes para un sistema de cadena:

Material / Material	Standard Norma	Grade Grado	Yield Strength Límite elástico [MPa]	Tensile strength Resistencia a la tracción [MPa]
HDG Carbon Steel / Acero al carbono GC	EN 10025*	S355J2*	355	510
Stainless Steel / Acero inoxidable	EN 10088*	1.4401*	240	540

* or equivalent / o equivalente

HDG – Hot Dip Galvanised acc. ISO 1461 / GC - Galvanizado en caliente según ISO 1461



Anchors Anclajes [n x Mnn]	A [mm]	B [mm]	ØC [mm]	D [mm]	E [mm]	ØF [mm]	Weight Peso [kg]
4 x M22	250	170	26	30	45	26	17
4 x M36	310	200	40	45	65	44	34
4 x M48	430	300	58	65	90	55	96
4 x M52	450	300	60	75	90	62	126
4 x M64	480	300	70	90	90	75	167
4 x M72	550	330	90	100	100	75	237

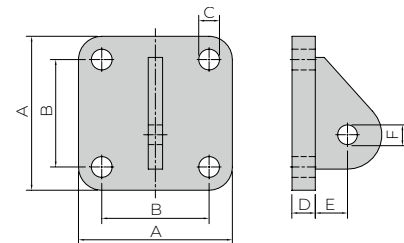

Double Chains Brackets / Soportes para dos sistemas de cadenas:

Material / Material	Standard Norma	Grade Grado	Yield Strength Límite elástico [MPa]	Tensile strength Resistencia a la tracción [MPa]
HDG Carbon Steel / Acero al carbono GC	EN 10025*	S355J2*	355	510
Stainless Steel / Acero inoxidable	EN 10088*	1.4401*	240	540

* or equivalent / o equivalente

HDG – Hot Dip Galvanised acc. ISO 1461 / GC - Galvanizado en caliente según ISO 1461



Anchors Anclajes [n x Mnn]	A [mm]	B [mm]	ØC [mm]	D [mm]	E [mm]	ØF [mm]	ØG [mm]	Weight Peso [kg]
4 x M36	310	200	42	30	50	35	26	25
4 x M42	350	230	48	40	70	45	35	41
4 x M48	390	250	58	45	80	48	38	54
4 x M56	440	290	66	50	90	60	45	82
4 x M64	520	350	75	65	105	65	50	150

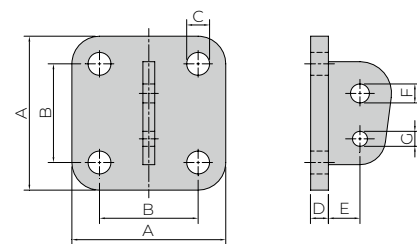

"U" TYPE ANCHORS ANCLAJES EN "U"

Cast-in "U" anchors for new concrete / Anclajes "U" para embeber en hormigón nuevo:

Material / Material	Standard Norma	Grade Grado	Yield Strength Límite elástico [MPa]	Tensile strength Resistencia a la tracción [MPa]
HDG Carbon Steel / Acero al carbono GC	ISO 898*	4.8*	320	400
Stainless Steel / Acero inoxidable	EN 10088*	1.4401*	240	540

* or equivalent / o equivalente

HDG – Hot Dip Galvanised acc. ISO 1461 / GC - Galvanizado en caliente según ISO 1461



ØE [mm]	A [mm]	B [mm]	C [mm]	D [mm]	Weight Peso [kg]
30	110	300	410	80	6,4
40	140	420	560	100	13,5
50	170	500	670	100	23,5
60	200	600	800	110	40,0
70	305	700	1005	120	69,5
80	310	800	1110	140	100,5
90	315	900	1215	150	136,0

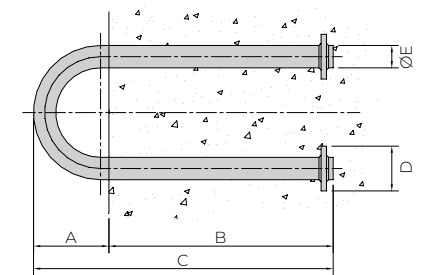

"U" Anchors for existing concrete / Anclajes "U" para hormigón existente:

Material / Material	Standard Norma	Grade Grado	Yield Strength Límite elástico [MPa]	Tensile strength Resistencia a la tracción [MPa]
HDG Carbon Steel / Acero al carbono GC	EN 10025*	S355J2*	355	510
Stainless Steel / Acero inoxidable	EN 10088*	1.4401*	240	540

* or equivalent / o equivalente

HDG – Hot Dip Galvanised acc. ISO 1461 / GC - Galvanizado en caliente según ISO 1461



ØE [mm]	A [mm]	B [mm]	C [mm]	ØD [mm]	Weight Peso [kg]
30	110	360	470	40	6,0
40	140	500	640	50	13,0
50	170	600	770	60	25,0
60	200	700	900	70	43,0
70	305	800	1105	80	66,0
80	310	950	1260	90	107,0
90	315	1050	1365	100	146,0

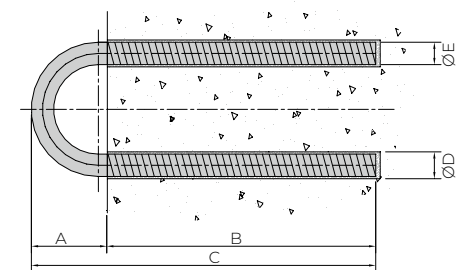

* drilled hole for resin / agujero para la resina

CHAINS

CADENAS

Open Link Chains / Cadenas sin concreto:

Material / Material	Coating protection / Recubrimiento
Carbon Steel / Acero al carbono	Hot Dip Galvanised acc. ISO 1461 / Galvanizado en caliente s/ ISO 1461



ØD [mm]	A [mm]	B [mm]	Test load [kN] Carga de prueba	Breaking load [kN] Carga de rotura	Weight [kg/m] Peso
16	64	25,6	66,2	132,3	5,2
18	72	28,8	78,9	157,8	6,5
20	80	32,0	102,4	204,8	8,2
22	88	35,2	125,4	250,9	10,0
24	96	38,4	149,9	298,9	12,5
26	104	41,6	175,4	350,8	14,0
28	112	44,8	203,8	406,7	16,5
30	120	48,0	234,2	467,5	19,0
32	128	51,2	265,6	531,2	21,5
34	136	54,4	299,9	599,8	24,0
36	144	57,6	336,1	672,3	26,0
38	152	60,8	374,4	748,7	29,5
40	160	64,0	414,5	829,1	33,0
42	168	67,2	457,7	915,3	37,0
44	176	70,4	502,2	999,6	41,0
46	184	73,6	548,8	1097,6	45,0
48	192	76,8	597,8	1195,6	49,5
50	200	80,0	648,8	1239,6	53,5

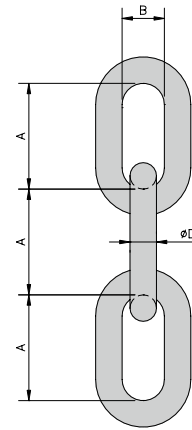

Stud Link Chains / Cadenas con concreto:

Material / Material	Coating protection / Recubrimiento
Carbon Steel / Acero al carbono	Hot Dip Galvanised acc. ISO 1461 / Galvanizado en caliente s/ ISO 1461



ØD [mm]	A [mm]	B [mm]	Grade 2 / Grado 2		Grade 3 / Grado 3		Weight [kg/m] Peso
			Test load [kN] Carga de prueba	Breaking load [kN] Carga de rotura	Test load [kN] Carga de prueba	Breaking load [kN] Carga de rotura	
40	240	144,0	640	896	1280	1280	37,6
42	252	151,2	703	981	981	1400	39,4
44	264	158,4	769	1080	1080	1540	43,5
46	276	165,6	837	1170	1170	1680	47,6
48	288	172,8	908	1270	1270	1810	52,3
50	300	180,0	981	1370	1370	1960	56,2
52	312	187,2	1060	1480	1480	2110	60,4
54	324	194,4	1140	1590	1590	2270	65,1
56	336	201,6	1220	1710	1710	2430	70,0
58	348	208,8	1290	1810	1810	2600	75,9
60	360	216,0	1380	1940	1940	2770	81,8
62	372	223,2	1470	2060	2060	2940	85,9
64	384	230,4	1560	2190	2190	3130	91,5
66	396	237,6	1660	2310	2310	3300	97,3

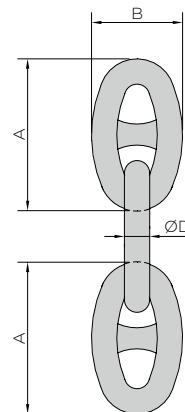

SHACKLES & TENSIONERS

GRILLETES Y TENSORES

High Strength Shackles / Grilletes de alta resistencia:

Material / Material	Coating protection / Recubrimiento
Carbon Steel / Acero al carbono	Hot Dip Galvanised acc. ISO 1461 / Galvanizado en caliente s/ ISO 1461



ØD [mm]	A [mm]	B [mm]	ØC [mm]	Test load [kN] Carga de prueba	Breaking load [kN] Carga de rotura	Weight [kg] Peso
16	51	26	20	63,8	191,3	0,7
20	58	32	22	93,2	279,6	1,1
25	82	42	28	166,8	500,3	2,5
28	89	46	32	186,4	559,2	3,5
32	94	51	35	235,4	706,3	4,9
35	115	57	40	264,9	794,6	6,5
40	127	60	45	333,5	1000,6	8,6
45	150	73	50	490,5	1471,5	14,2
50	171	83	57	686,7	2060,1	18,9
65	203	105	70	1079,1	3237,3	37,9

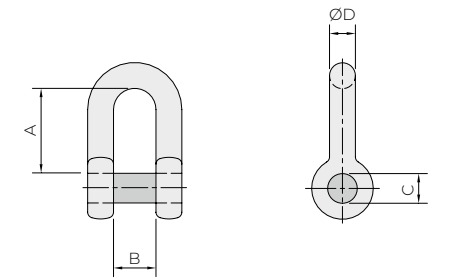

Tensioners / Tensores:

Material / Material	Standard Estándar	Grade Grado	Yield Strength [MPa] Límite elástico	Tensile strength [MPa] Resistencia a tracción
HDG Carbon Steel / Acero al carbono GC	EN 10025*	S355J2*	355	510



* or equivalent / o equivalente

HDG - Hot Dip Galvanised acc. ISO 1461 / GC - Galvanizado en caliente según ISO 1461

Size Tamaño [Mnn]	A [mm]	B [mm]	ØC [mm]	D [mm]	E [mm]	Weight [kg] Peso
M14	145	111	14	90	70	2,0
M16	171	122	16	100	80	2,0
M18	195	137	18	110	90	4,0
M22	240	162	22	130	110	5,5
M24	230	186	24	150	120	6,5
M27	275	210	27	170	135	11,0
M30	285	233	30	190	150	13,0
M33	320	253	33	205	165	17,0
M36	360	273	36	220	180	25,0
M42	370	292	42	230	210	32,0
M45	430	326	45	260	225	44,0
M48	400	370	48	300	240	57,0
M52	500	386	52	310	260	69,0
M56	560	402	56	320	280	85,0

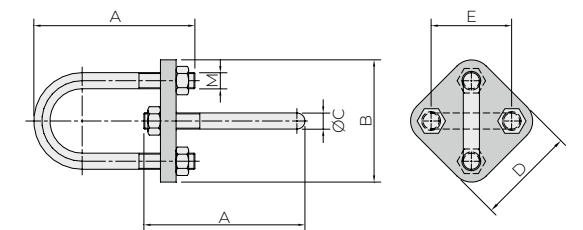

OTHER PROSERTEK'S PRODUCTS' CATALOGUES / OTROS CATÁLOGOS DE PRODUCTOS DE PROSERTEK:

- **BOLLARDS FOR THE MOORING OF VESSELS / BOLARDOS PARA AMARRE DE BUQUES**
- **QUICK RELEASE HOOKS / GANCHOS DE ESCAPE RÁPIDO**
- **BAS BERTHING AID SYSTEM / BAS SISTEMA DE AYUDA AL ATRAQUE**
- **GANGWAY SYSTEMS SELF-PROPELLED SHIP ACCESS GANGWAYS / PASARELAS AUTOPROPULSADAS DE ACCESO A BUQUES**
- **PASSENGER BOARDING BRIDGES FOR SHIP TO SHORE TRANSFER / PASARELAS DE EMBARQUE DE PASAJEROS PARA TRÁNSITO BUQUE-TIERRA**



**HEADQUARTERS
OFICINAS CENTRALES**

Iparraguirre, 59 – 5º
48980 Santurtzi (Bizkaia)
Spain
Tel. (+34) 944 831 775
Email: prosertek@prosertek.com

www.prosertek.com

PROSERTEK AMERICA

5100 Westheimer
Suite 200
Houston, TX 77056
United States
Tel. +1 713 969 5019
Email: prosertek@prosertek.com

PROSERTEK OCEANIA

45 Ventnor Avenue
West Perth WA 6005
Australia
Tel: +61 (0) 8 9429 8804
Email: info@prosertek.com.au